



Measuring Up!

Building Metric Measurement Skills Through Art
at Harms Elementary School
Lessons from the Detroit Connections Project
The University of Michigan School of Art & Design

Measuring Up!
Building Metric Measurement Skills
Through Art at Harms Elementary School

Lessons from the Detroit Connections Project
The University of Michigan School of Art & Design

Written by Ceci Méndez and Janie Paul
Designed by Jennifer Pirch
Photographs by Jennifer Pirch and Ceci Méndez
Illustrations by Ceci Méndez

Project Supervisor: Janie Paul
Site Coordinator: Ceci Méndez
Project Developers: The Detroit Connections Class
2001-2002 University of Michigan
School of Art & Design



This project has been generously funded by the Communities in Schools Harms Elementary 21st Century Grant, and Arts of Citizenship, and the School of Art & Design at the University of Michigan.

© 2003 All rights Reserved

Janie Paul
Ceci Méndez
Jennifer Pirch

Please contact us if you would like:

- more copies of Measuring Up or the Art/Science Curriculum for the Harms Elementary After School Program
- information on the forthcoming guide in this series, “Shape Soup,” which describes our math-integrated mural process as well as other smaller-scaled art projects and activities.
- to find out more about the Detroit Connections class at the University of Michigan

Janie Paul

Director of Community Connections
Assistant Professor
janiep@umich.edu

Ceci Méndez

Adjunct Assistant Professor
Arts of Citizenship Site Coordinator
cmendez@umich.edu

School of Art & Design
2000 Bonisteel Blvd.
Ann Arbor, MI 48109
(734) 764-0397



Acknowledgements

This project was made possible through the collaboration of many people from Harms Elementary School in Detroit and the University of Michigan in Ann Arbor.

At Harms School we would like to thank Principal Patricia Diaz; Janet Ray, Director of Communities in Schools; Phil Leonard, Director, Communities in Schools at Harms; Dora Badger, Director of the Afterschool Program; Fourth Grade teachers Elizabeth Calcaterra and Corinne Davis; School Secretary Teresa Miley; and all the other teachers and staff at Harms.

At the University of Michigan we would like to thank Bryan Rogers, Dean, School of Art & Design; David Scobey, Director of Arts of Citizenship; Karis Crawford, Program Associate of Arts of Citizenship; Laura Taylor, Financial Manager of Arts of Citizenship; Anthony Smith, co-facilitator of Detroit Connections; and Sophie Rasul and Heather Vivio, contributing photographers.





Student Participants

The Alebrije Project Fall Semester

Harms Elementary School

Gloria Asher, Giovanni Calandrino, Anna Herman,
Angel Jurado, Maria Jurado, Carlos Martinez, Laura Sanchez

University of Michigan

Erica Duffy, Andrez Garces, Megan Kippola,
Molly Lewandowski, Jennifer Pirsch

The Bookmaking Project Winter Semester

Harms Elementary School

Gloria Asher, Saul Barajas, Edwin Barerra, Giovanni
Calandrino, Dolores Gonzalez, Estefania Gonzalez, Javier
Gonzalez, Jasmine Guzman, Anna Herman, Maria Jurado, Jose
Leon, Carlos Martinez, Jesus Martinez, Miranda Rasnick,
Maleny Rodriguez, Ana Sanchez, Jose Villareal

University of Michigan

Natalie Escamilla, Andres Garces, Sandra Matusiak, Heather
McWilliams, Julie Morelli, Elvontio Peterson,
Jennifer Pirsch, David Yu



Table of Contents

About Measuring Up.....	1
Project Guidelines.....	3
An Introduction to Alebrijes.....	4
Lesson 1 My Favorite Animal Is.....	5
Lesson 2 Imagining an Alebrije.....	7
Lesson 3 Break it Down.....	11
Lesson 4 Enlarge Your Alebrije.....	13
Lesson 5 Construction From the Inside Out.....	15
Lesson 6 Covering Your Alebrije in Mesh.....	19
Lesson 7 Wings, Legs, Arms, Hands, Feet.. The Construction of Other Alebrije Parts.....	23
Lesson 8 Putting it All Together.....	25
Lesson 9 Make Your Own Glue! A Recipe for Papier-Maché Paste/Engrudo.....	27
Lesson 10 Putting on the Papier-Maché	31
Lesson 11 Final Attachments and Papier-Maché.....	33
Lesson 12 Patterns Through Movement.....	35
Lesson 13 PaTtErNs, PaTtErNs, and more PaTtErNs!.....	37
Lesson 14 Painting the Alebrijes.....	39
A Conclusion to Alebrijes.....	44



An Introduction to Bookmaking.....	46
Lesson 1 Symbolize Your Movement: movement, line pattern, shape & symbol.....	47
Lesson 2 What Do You Love About Books?.....	51
Lesson 3 Mobilize Your Vision.....	53
Lesson 4 Brainstorming Book Covers.....	55
Lesson 5 Building Book Covers.....	57
Lesson 6 Choosing Cover Colors.....	61
Lesson 7 Decorating the Covers.....	65
Lesson 8 Making a Page Template.....	69
Lesson 9 Folders for Treasures.....	71
Lesson 10 Mini Book Making.....	75
Lesson 11 Let's Get Graphics.....	77
A Conclusion to Bookmaking.....	80



About Measuring Up...

Measuring Up is the second in a series of curriculum guides produced by the Detroit Connections Project at the University of Michigan's School of Art and Design. This series began in 2000 as a collaboration between The University of Michigan School of Art & Design the principal and the Communities in Schools program at Harms Elementary School in Detroit. Harms School principal, Patricia Diaz, identified science as the childrens' weakest area of performance on the MEAP (Michigan Educational Assessment Program) test. We were asked to create an art curriculum that would strengthen science skills for the children participating in the after school program. This resulted in the Art and Science Curriculum for Harms School, which we completed in 2001. For the next academic year, Mrs. Diaz identified metric measurement as the next most important academic area to work on. We designed a year-long curriculum for an after school club which we called Metric Arts consisting of two long term projects, one for the fall semester and one for the winter semester. These two projects, documented in this guide, were designed to combine concrete skills in measurement with an imaginative artistic experience that includes visual thinking and hands-on creation.

The work on this project was integrated into the Detroit Connections Class at the University of Michigan's School of Art and Design, taught by Janie Paul and Ceci Méndez. In this class, college students meet once a week in class to plan and prepare for their projects and travel once a week to Harms School to work for an hour and a half with the children in the Metric Arts afterschool club. This book is a documentation of our work and a guide for others who wish to use the projects in their schools, camps, community centers, and other programs.

The first semester was spent making Alebrijes, which are large papier maché sculptures based on a tradition rooted in Mexico. These were made collaboratively by small groups of two, three or four children. In the second semester, each child constructed a book that was designed to hold their visions and dreams for their futures - who they are, who they want to become and what kind of careers they might want to explore. Each project was very much an exploration in art and mathematical skill building, with an emphasis on metric measurement. This book serves as both documentation of our experiences and as a guide for anyone who wishes to use it for their own projects.



The fundamental idea behind our projects is that, particularly in primary education, there are concepts and processes shared by art and math. Quantitative and geometric skills are deeply embedded in many kinds of art making. Likewise, there are tremendous visual and design possibilities in the exploration of basic math concepts. By integrating art and math holistically into personal, concrete projects one becomes necessary to the other, and skills in measurement are built through a sustained, creative practice.

In order to do this, we had a very high teacher to student ratio. In the first semester, there were five college students working with seven Harms students. In the second semester it was seven to fifteen. We usually started the session off in a large circle, talking about our plans for the day, looking at visual references, giving some general instructions, or, especially in the beginning, playing a short game. Then we broke into small groups composed of one college student with two to five children. We made use of this situation to build Alebrijes on quite a large scale and to make books with the students on a very individualized and personal basis. Especially in the Alebrije project, students were encouraged to share ideas, work collaboratively, and rely upon one another for accomplishing tasks, or in the division of labor. Ideally, these projects should be carried out in a similar classroom, after school program, or camp situation. But even without such a high student/teacher ratio these projects are still very possible. Throughout the lessons we have made notes where materials or choices can be adjusted accordingly to fit available material and or human resources. This guide is meant to serve either as a straightforward recipe for those wishing to replicate the projects, or for those who may want to adapt, simplify, or complicate them.

It is also important to note that the Alebrije and Book projects can be taught and supervised by project leaders who are not artists. We tried to be as clear as possible in documenting and describing our process and in showing examples of the students' work so that non-artists would feel comfortable taking on an art project. As a result, it is filled with images from our creative process, as well as step-by-step instructions.

Each lesson in this guide represents one of the hour and a half sessions with the children we worked with. This time of course, will vary depending on the scale in which you choose to do the projects, the materials you use, and the number of students you are working with. There were times when we worked in between sessions to further some

of the work the children had begun. But we never took steps that they themselves had not initiated.

This book is a summary of our experiences and a guide for you. In it, you will not encounter all the unexpected events that will inevitably happen if you combine groups of college students and groups of children in an after school program. Children get sick, they have to leave the session early, someone brings their seven year old brother who wants to play basketball and run around the classroom, there is an unexpected half-day or fire alarm, a college student has an important interview and can't come to the workshop, the children can't agree on a color... But it was partly through working through all these challenges while progressing through the projects that brought our whole group together. Each week we shared the pleasure of seeing our projects take on more form and were exhilarated at their final completion. In the end, each child was recognized and celebrated. We all felt the sense of peace that comes with the completion of a process that has a flow in time and then takes its physical shape in the world. We hope that our efforts to document and explain our process will provide a similarly wonderful art making experience for your group.

Project Guidelines

1. If possible, do these projects in small groups so that each child gets a substantial amount of help through the whole process. We formed groups in which one college student worked with two or three children. This enabled us to do more complex projects than we would have been able to do otherwise. If you are the only teacher, you may want to simplify or modify the projects, do one piece of a project, or have your students work in small groups.
2. This guidebook is designed for fourth and fifth grade, but could be adapted for either younger or older students. We encourage you to make appropriate adjustments depending upon age, abilities, time constraints, availability of materials, and number of teachers or group leaders. We have made notes under the heading of “Variations” wherever a different material may save time and money, as well as make the project easier to do.
3. To do the projects as we have designed them, follow the lessons for each section in the sequence that it is presented in the manual. Both the Alebrije Section and the Bookmaking Section are designed with specific beginnings and endings, and lessons must be carried out accordingly unless you have chosen to modify the whole project in your own way. Exceptions or lessons that can be done concurrently are always noted.
4. We strongly recommend doing the project lessons yourself before doing them with the students. This has two major benefits: to assess the time needed to do the lesson, and to create a sample for the students to study before they begin each part of the process.
5. The vocabulary words in this guidebook may vary slightly from the way you define them. What is important are the underlying concepts and principles. We imagine that you will be free to either adopt our words or find a way to incorporate them into your language.
6. Wherever possible, students should be encouraged to do their own measuring and cutting, except when tools such as wire cutters or razor blades may be required. These special instances are noted in the “Materials” section.



An Introduction to Alebrijes...

Alebrijes, an art form with a rich and colorful history, were invented in Oaxaca, Mexico, by a man named Don Pedro Linares in the 1940's. Alebrije is the name given to a creature that is not easily identifiable as a specific animal; rather, it is a combination creature made up of many parts of different animals. Don Pedro Linares invented Alebrijes after having seen many of these creatures in his dreams and then being suddenly cured of a terrible illness. As a way to give thanks to his salvation, he began to bring these animals to life out of gourds and glue made from a natural flour and water paste. You can find a more detailed version of this history to read and share with your students in Lesson 2 of the "Imagining an Alebrije!" Section.

We have modified Don Pedro's process to make it more do-able for school children. While Don Pedro Linares made his Alebrijes entirely from many layers of hardened papier-maché, we created an armature and then covered it with a papier-maché covering. Instead of using ordinary materials such as natural gourds that are abundant in Mexico, we used recycled materials and cans to form some of the body parts of our creatures.

Because our student/teacher ratio was so favorable (5 teachers to seven students), we were able to work on a relatively large scale. Our Alebrijes were several feet tall and/or wide. You should base your decision about scale on how much time you have and how many people you have to work with the children.

Since the class will be working in collaborative groups, students should know from the beginning that no one person will be taking the Alebrijes home. In our case, the children made small creatures out of clay at the end of the semester to keep as symbols of their experience. Students also received certificates of recognition and congratulation for their hard work. The Alebrijes remained in Harms School for everyone to enjoy. We chose to make Alebrijes for the cultural relevance to our primarily Mexican population at Harms. But all students can benefit from the learning of this art form. It is a wonderful opportunity for challenging and deeply satisfying collaborative work!

My Favorite Animal Is...

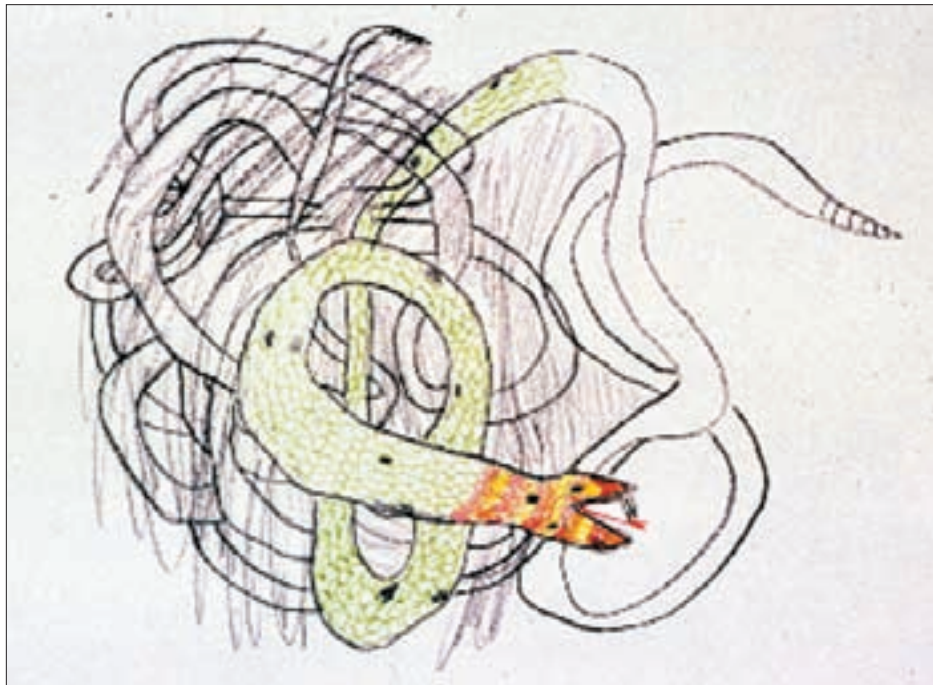

This is the introductory lesson to the unit on “Alebrijes.” It involves both a movement exercise and a drawing session. We found that the movement exercise served as a great icebreaker and got students sharing ideas in a fun and animated way.

If people have trouble coming up with a movement, have them say their animal and the group can help come up with a motion. In this way, the group movement exercise allows for people to share their ideas and also for all to participate with suggestions.

Skill
speaking in front of a group, drawing

Objective
To create a picture of your favorite animal

Vocabulary
movement- an action of the body or limbs made to express or emphasize an idea or feeling.

Materials
paper
colored pencils
markers
crayons

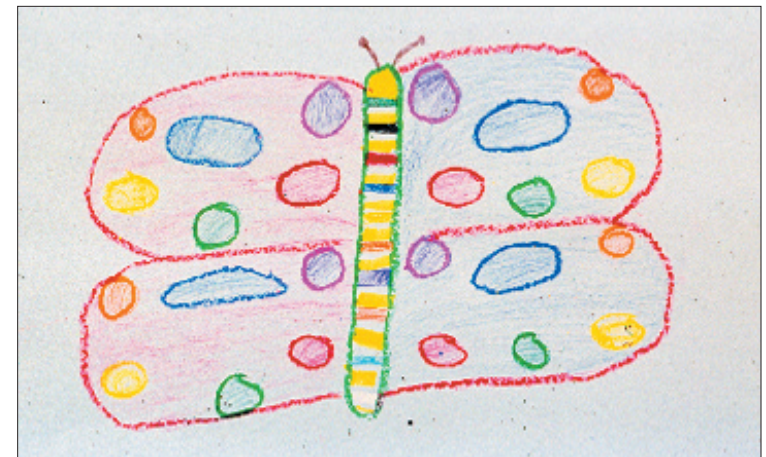

Laura's Butterfly

Activity

Part I: Group Movement Exercise

1. Students sit in a circle. Have everyone close their eyes and picture an image of their favorite animal. Ask students to imagine how the animal moves.
2. Everyone opens their eyes. The first student says their name and then does a movement to reflect the movement that their chosen animal makes. Have other students guess what their animal might be.

For example, Laura says her name then spreads her arms wide and flaps them forward and backward. People guess “bird,” “butterfly.” Laura confirms that the butterfly is her favorite animal.

3. All the students in unison repeat Laura’s name and say “butterfly,” while repeating her butterfly movement.
4. The next student, Carlos, introduces himself and makes his motion, repeating the same process the group has gone through during Laura’s turn.
5. As a group, everyone repeats Laura’s name/animal/movement as well as Carlos’ name/animal/movement.
6. Repeat this process (each time beginning with the first person in the circle and ending with the most recent person) until everyone has had a turn, and all students have said in unison the full circle of names, animals, and motions. We found that we all had a really fun time trying to remember everything all together.

For example, a sampling of this exercise might look something like this:

“Laura. Butterfly.” (as we all flap our extended arms forwards and backwards.)

“Carlos. Dragon.” (as we all open our hands wide in front of our mouths to show a dragon’s teeth.)

“Gloria. Turtle.” (as we all swim slowly with short arms under water.)

“Gino. Snake.” (as we all slither our arms along the ground in a wavy rhythm.)

Part II: Drawing

Have each student make a drawing of their animal on paper using pencils, markers, and/or crayons. Have them be as detailed and imaginative as they like. Things for students to think about as they draw their animal:

- What parts of your animal are you especially inspired by?
- How might you depict some of the movement that you made into your drawing?
- What would your animal look like from different angles?

If the student has more than one favorite animal, encourage them to make more than one drawing.



Imagining an Alebrije



Maria and Anna created a creature that was part dog, part monkey, part elephant.

Students are now ready to combine their independent drawings into collaborative ones. After a discussion students will work together in small groups and each group or pair will compose an animal drawing that is a combination creature, a hybrid of at least two animals, made in the spirit of the Alebrije tradition. These collaborative drawings will be the plans for the Alebrije creatures that the students will build.

The groups formed at this stage of the project will remain the same for the duration of the project. Students can pair or group up on their own or you may want to form the groups yourself.

Before starting this activity, you may want to get into a circle and go through everyone's name, motion, and animal all together again. This can serve to help everyone remember the variety of animals chosen and to get the group warmed up for the activity following the discussion.

Skill
collaborative art work

Objective
To create collaborative drawings that combine students' original animal drawings

Vocabulary
combine- to unite, to become one

invention- a creation of the imagination

Materials
large paper
pencils
crayons
markers

Discussion

Share the story of the Alebrijes while showing the images on the following pages. It may be that some students are familiar with this art form and have heard stories of its origins. We found this to be true in our case. Two students who had prior knowledge of Alebrijes shared what they knew about them with the class.

The following page can be photocopied for your students.

What is an Alebrije?

An Alebrije is a creature made up of many different kinds of animals. Alebrijes are very colorful, brightly patterned creatures with many interesting features, such as horns, tails, and sometimes many heads and hands.

Alebrijes were invented in a place called Oaxaca, Mexico, by a man named Don Pedro Linares in the 1940's. Don Pedro became sick and fell seriously ill. One night, he began to have many dreams in which wonderful and fantastical creatures appeared to him. He couldn't tell what in the world they were. One of them had parts of a dragon, and a dog, and a snake. Others had horns and huge wings. Others had multiple heads with many eyes and hands. All of them were brightly patterned with many colors. The creatures came night after night to visit Don Pedro in his dreams. After several dreams, Don Pedro started to feel better, until soon he was cured. When he felt completely better, he decided to pay tribute to the creatures he considered his helpers, and decided to bring them to life. He started making the creatures he had seen in his dreams and he called them Alebrijes.

Don Pedro Linares set to work to make many Alebrijes. He brought them to life out of common materials such as gourds with round bodies and long twisting necks. He would cover these in paper with a glue made from flour and water. When the paper dried he would cut out the gourds, seal the paper shell, and attach different shapes to one another to create the creature forms. When those were dry he would paint them with the same brilliant patterns and designs he had seen in his dreams.

Today, the tradition continues. Many Alebrijes, like those you see here, are made out of wood, and they are much smaller than those that Don Pedro originally made. You can find Alebrijes in the town of Oaxaca and in places all over Mexico and in the rest the world.

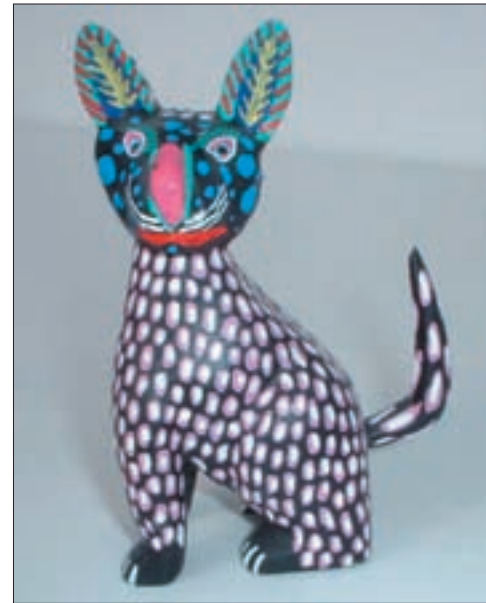

a cat-rabbit alebrije



a fire-breathing winged and horned dog-dragon alebrije



a lizard alebrije



notice the abundant and colorful patterns



a frog alebrije

After showing some of the images of Alebrijes from Mexico, ask some questions to generate a discussion:

- What do you notice about these creatures?
- What is special about their features?
- How many multiples of body parts does each creature have?
For example, one Alebrije may have two heads, another two sets of ears.
- What do you notice about how they are painted?
- What are some words you would use to describe these Alebrijes?
- Pick one creature and ask the students to see if they can pick out the recognizable parts. For example, one creature looks like it is part dog, part dragon, with black boots and a pancake painted on its hands.
- If you could create a creature of any kind what would you make?

Activity

After the discussion, explain to the students that in small groups they will be drawing (and later building) their own Alebrijes.

1. In small groups or pairs, have students look at their drawings together. Ask students to note what they like most about each person's drawings.
2. Have students combine their chosen animals into a collaborative drawing that incorporates the parts and pieces of each person's animal. Students can also add parts of other animals that they like to their hybrid creatures.
3. Have students color in the collaborative Alebrije drawings.

Stress that the Alebrije is an invented animal, that no matter what the students come up with it is their collective creation. Their creatures can be anything they want them to be.



Laura and Gloria combined their original butterfly and turtle, but also decided to use a dolphin with three eyes as a central part of their Alebrije.



Gino, Carlos, and Angel made a three headed creature, the body of which they drew together. Each person made their own head.

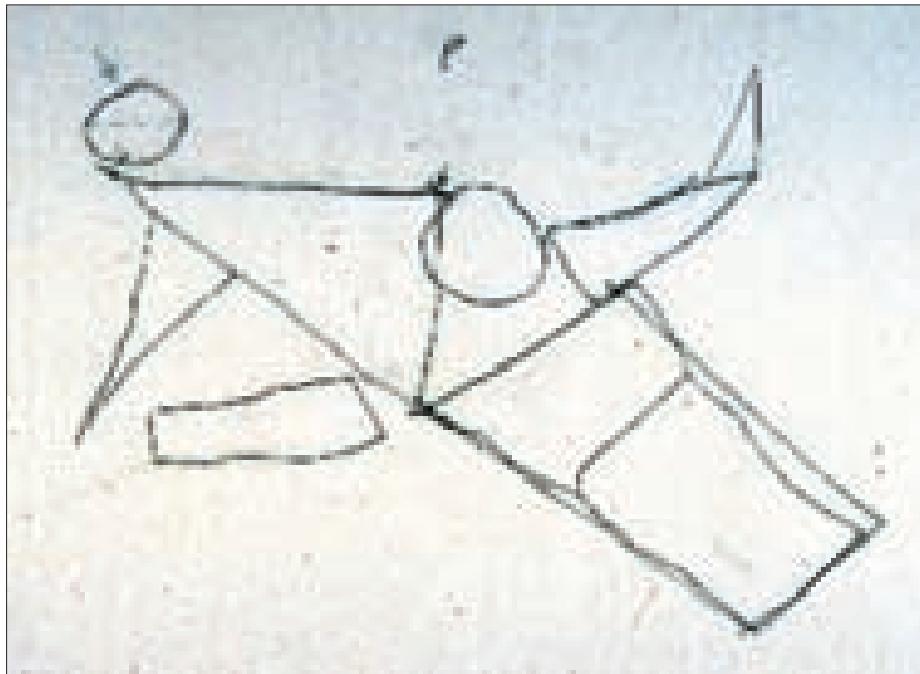

In this lesson students will work from the collaborative Alebrije drawings made in the previous class. Their task is to examine the detailed collaborative drawing and simplify it into an arrangement of basic shapes. It is useful for the students to see how a detailed and complex drawing can be broken down into essential parts. They will not only examine the simple shapes that make up the more complex drawing, they will also be able to see the relationships the basic shapes have to each other. This is a useful tool in and of itself, and also serves as preparation for future lessons.

Skill
shape recognition, metric measurement in centimeters (cm)

Objective
To create a drawing of simplified shapes based on the composite animal drawings; to make observations about shape relationships.

Vocabulary
form- structure; a bounded surface or volume

shape- a 2-dimensional area of space bounded on all sides

size- physical extent or bulk; dimensions

basic- forming the essence of; fundamental

detail- the specifics or particulars of something

Materials
the Alebrije drawings
tracing paper
pencils

Activity

Students will work in the groups formed in the last lesson. Each student can be responsible for the part of the drawing they contributed to, or else all steps can be done by all members of the group together. You can decide based on how your students work best together.

1. Each group lays out their Alebrije drawing. Have the students observe and see if they can immediately isolate any shapes that are prominent or obvious.

For example, the body of the dragon-creature, while not perfectly uniform, seemed rounded and resembled something like an oval according to Gino, Carlos, and Angel.

2. Lay the tracing paper over the drawing. If the tracing paper is not big enough to cover the entire drawing, place the tracing paper on one part of the creature at a time, or have two people working on two different parts of the drawing at the same time.
3. Use a pencil to mark all the general shapes of the drawing onto the tracing paper. The original drawing placed below the tracing paper will act as a direct guide. Don't worry if all the shapes don't fit on one piece of tracing paper; use several and later students can tape them back together.

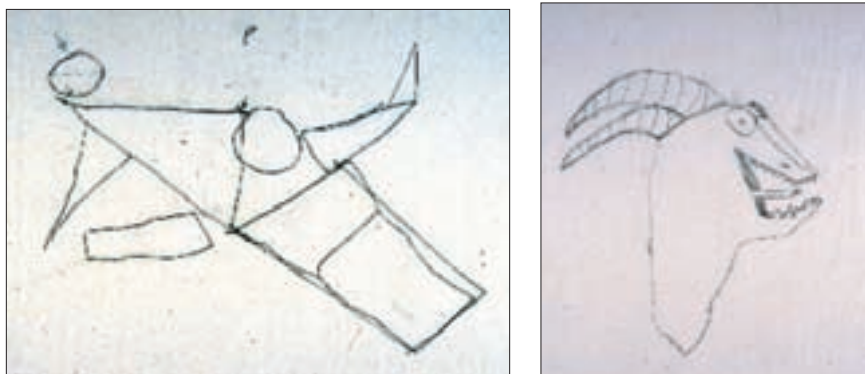

-Carlos' head (top right) is simplified into triangles and circular/oval shapes

-Angel's head (bottom left) becomes isolated into shapes: triangles, rectangles, and circles.

-Gino's head (bottom right) started to be a simplification, but Gino couldn't resist re-drawing his details!

4. Have students do some measuring of their shapes/Alebrije parts. Do as many measurements as possible.

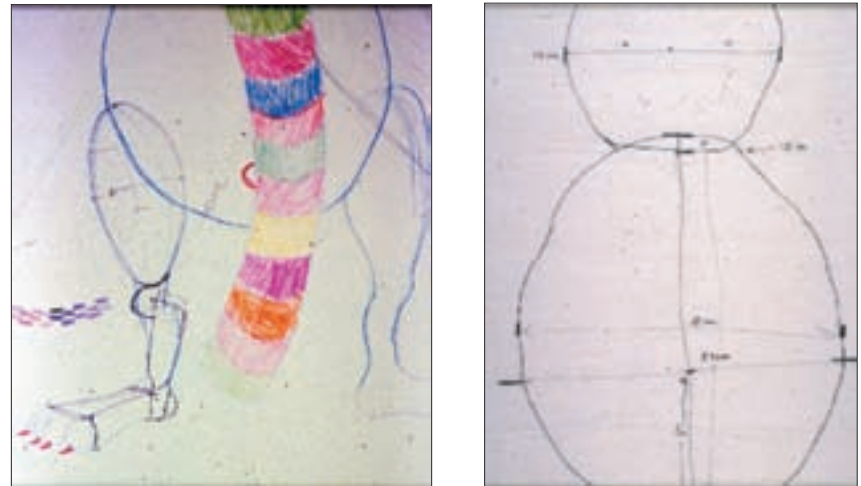

The adult leaders made sketch marks on the original drawing to help Maria and Anna see body parts as simple shapes. Then, Maria and Anna isolated the round shapes that make up the head and body and marked measurements in centimeters.

Ask students to consider the shapes they have drawn. For example:

- How many different sized circles do you have on your drawing?
- How many different sized three-sided shapes? What about squares and rectangle shapes?

If there are shapes that are similar, ask students to notice and talk about the sizes of the shapes. For example:

- What do they notice about the relationship between similar shapes?
- Is there a shape that is about twice as big as another shape?
- Is there a shape that is about half the size of another shape?

Ask each group to write down at least three observations related to size and scale from their shape drawings.

Enlarge Your Alebrije

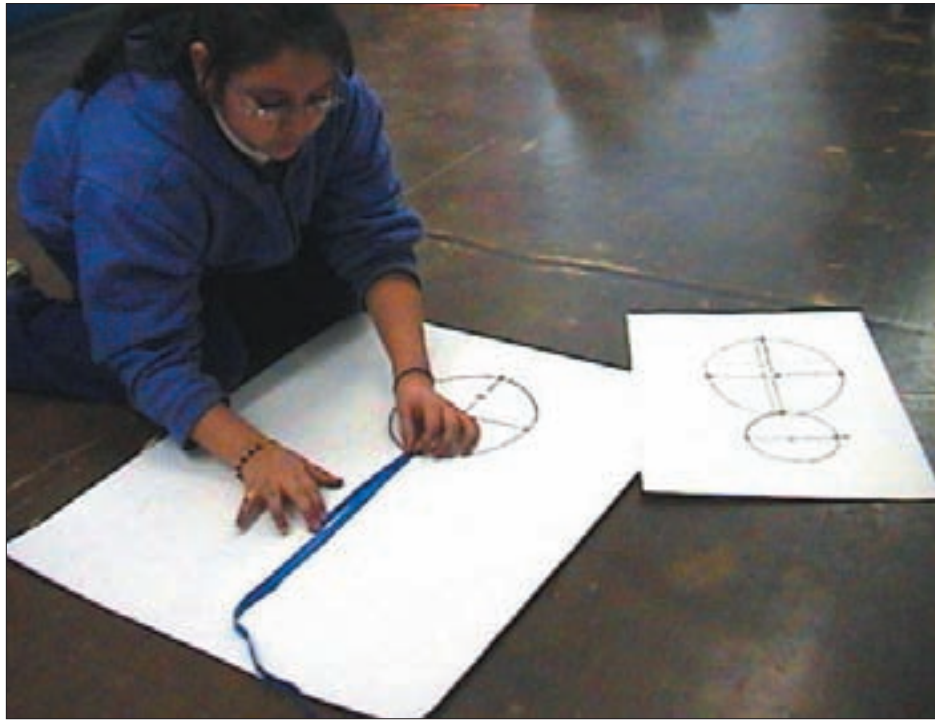

In this lesson, students will focus on enlarging the Alebrije drawings. This exercise builds upon the previous lesson in which students isolated their drawings into basic shapes.

Our students found a new size that was four times as big as the original. You can do as many enlargements as you have time for. Once students find their enlarged measurements, the original drawings can be referenced to talk about fractions. For example, if the new drawing is four times as big as the first drawing, then the first drawing is $\frac{1}{4}$ the size of the new drawing.

The students will use this enlarged drawing as a blueprint for their Alebrije construction.

Skill

metric measurement in centimeters (cm), fractions

Objective

To create a drawing of the alebrije creature that is four times the size of the original.

Vocabulary

about- reasonably close to; approximately

fraction- a comparison of parts to a whole

Materials

simplified shape drawings from previous lesson

pencils

flexible tape measure

large paper

Activity

The most important Alebrije parts to enlarge are the portions that form the main body and head(s.) These are the parts that will require an armature to be built out of wire in a future lesson. In all of our cases, the main body was some kind of circle or oval. The example we show below is an oval that formed the main body of Maria and Anna's Alebrije. The widest horizontal measurement of the body is 18cm. The widest vertical measurement is 21 cm:

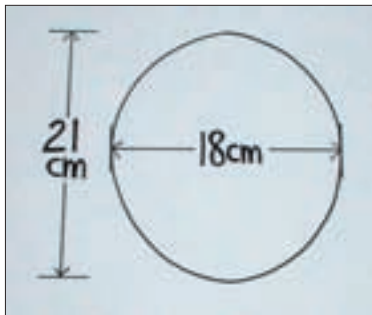

There are several ways to find an oval shape four times as large as the original. Below are the two ways we devised to enlarge the main body of the Alebrije drawings to four times their original size:

1. Multiply both the horizontal width and the vertical length, at their widest, by 2.

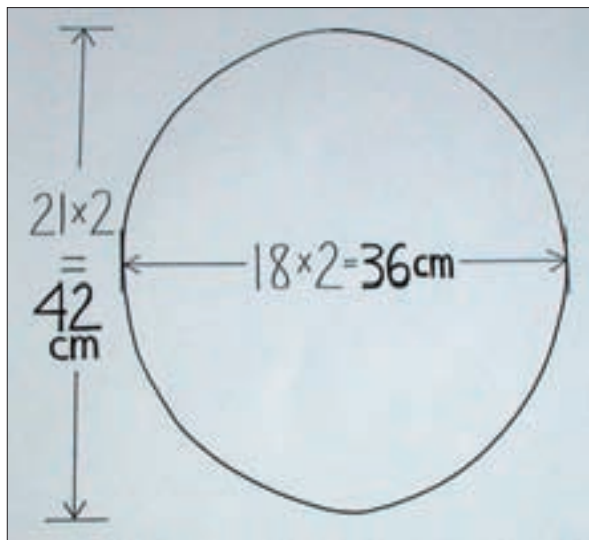

2. Use a flexible measuring tape to get a new measurement two times the widest horizontal width, as shown below. Then do the same to get a new measurement that equals two times the widest vertical length. Repeat the same process for circles that are heads, or for rectangular/square bodies.

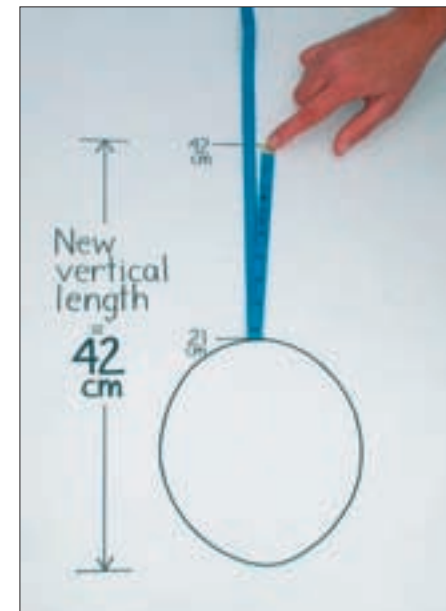

Smaller body parts that do not require armatures built (ie: those parts that do not have to sustain much weight) can be made out of found objects and materials and their sizes/proportions estimated. This will occur in future lessons.

Construction From the Inside Out



Students will now use the enlarged drawings as a blueprint for the Alebrije construction.

This part of the process is quite time consuming. Because of the nature of the tools, you will have to do some one-on-one work with each group, specifically where wire cutting is concerned. Today would be a great day to have as many assistants as possible!

Before beginning this process, we had a conversation with students about how we were about to create 3-dimensional creatures based on their 2-dimensional drawings. In order to hold together, each Alebrije has to have an internal structure which is like the skeleton found inside each of us. As a group students were asked to think about the internal structure that helps to support our muscles and veins and give form to our bodies. Eventually we came to the consensus that our bones provide the internal network of support that determines the sizes and shapes that we are. We had a good time coming to this realization as a group. If the students have a basic understanding of the skeleton, they will understand the need for an armature of their Alebrijes.

Skill

metric measurement in centimeters (cm); understanding of 2-dimensional shape and 3-dimensional volume

Objective

To measure and build the armatures for the Alebrijes

Vocabulary

perimeter- the distance around something

shape- a 2-dimensional area of space bounded on all sides

volume- the bulk or mass of an object

sphere- a volumetric figure that has the shape of a round ball

armature- the internal support structure of an object; the skeleton

Materials

pliable metal wire (about 1/8 -1/4 in. round; available at hardware stores.)

pliable metal wire (thin)

flexible measuring tapes

pencils

enlarged Alebrije drawings

duct tape (one roll per group)

scissors (at least one per group)

wire cutters (for teacher use only)

pliers (for teacher use only)

Activity

It is most likely that every group will have some kind of rounded figure in their drawing. Perhaps it is the circle of a head, or the oval shape of a body. In the example that follows, we use Maria and Anna's drawing to go step by step through the process for the oval body. All rounded shapes are created in the same way.

An oval shape becomes a sphere

1. Have students use the flexible measuring tape to measure the perimeter of the chosen round shape. (In this case only the oval body.)

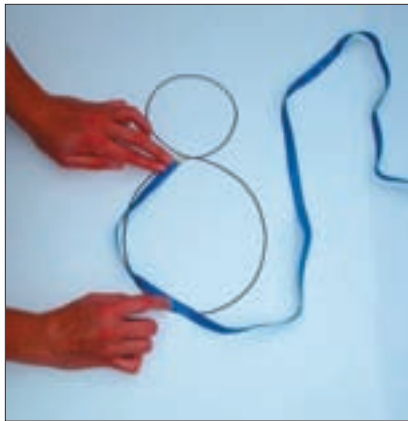

2. Measure this distance plus a few more centimeters of the thick bendable wire and cut the wire. (This is where students will need your assistance.)



3. Lay the wire over the round shape on the enlarged drawing, following the line. Mold the wire to follow the perimeter of the oval. Notice the few extra centimeters that overlap.



4. Connect the wire with the duct tape, making the joint overlap since there are a few extra centimeters of wire. This is so that the joint will be strong. (The duct taping process may need a couple of student hands: someone to hold it, someone to cut it.)



5. Repeat steps 2-4 two more times, so that each group now has three taped circles/ovals made out of wire.



6. Have a discussion with students about how these three wire circles, when put together a certain way, will create a sphere. Do a demonstration by inserting one circle into the other, then adding the third to show them how a volume is made from the three flat oval pieces. Or if you have previously covered the concept of volume in your class, ask the students how they would combine the three circles to make a sphere.



7. Using small strips of duct tape, connect the three wire circles at the top and bottom to form the structure of the sphere. You may want to use several pieces of tape for an extra sturdy joint. (Also, it may be easier to tape together two of the wire circles first. Once these are in place, then add the third. You may need to bend one of the circles a bit to make it fit inside the others. This is simple because the wire you get should be pliable enough to do this.)

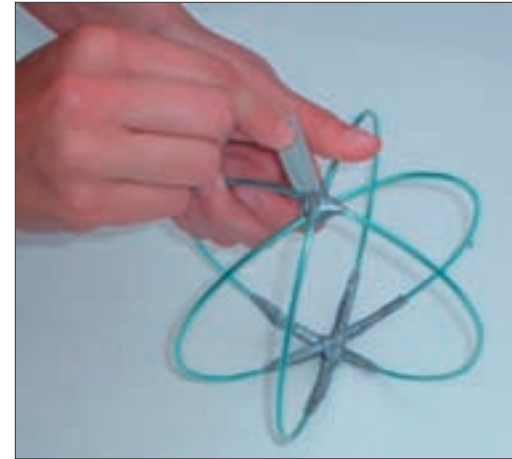

Now you have completed the first part of the structure for a three dimensional volume for the Alebrije.

For a larger sphere or rounded form, you will want students to reinforce the skeleton with some thinner wires that serve as cross supports. To do this, at each joint, tape the thin wire to the structure made with thicker wire. Doing this in two places will ensure that the wire circles stay in place and it will strengthen the overall structure.

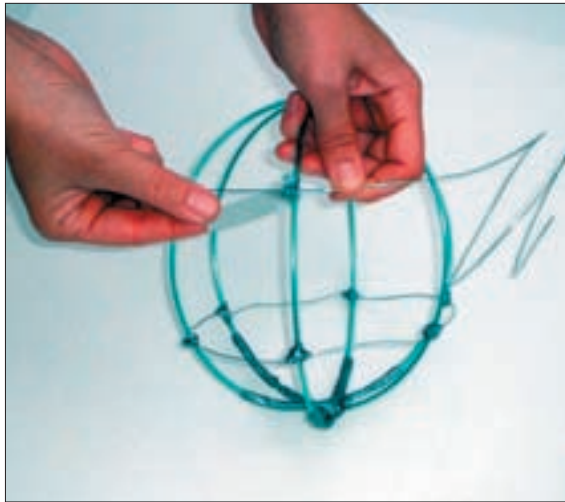

Now you have a strong internal structure for the Alebrije. This is what the skeletal structures of the head and body can look like after completing the previous steps for both the rounded head and the oval body.

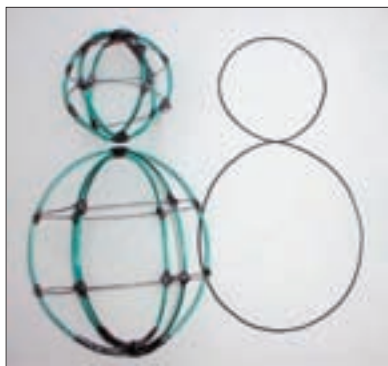

Variation

If you have the time and the resources, you can make variations of heads and bodies that are not uniformly rounded. Below is an example of a frame built out of wire and tape that became one of the three heads for the three-headed Alebrije.



Tips to remember:

- The stronger and more complex a structure you have, the better form your Alebrije will take in the subsequent steps.
- Make sure that no wire ends are poking out!! If there are any, cut them off and/or cover them with a layer or two of duct tape.

Lesson 6

Covering Your Alebrije in Mesh



Now that the armatures are built, it is time to cover them with a mesh material. The mesh covering will enclose the wire armature and is meant to be a support for the paper mache covering which comes in a future lesson.

The mesh covering should be done on anything that is built of a wire frame. As we mentioned in a previous lesson, many of the forms may be rounded or spherical. The process for covering a round armature with the mesh is outlined in this lesson.

Skill

metric measurement in centimeters (cm)

Objective

To cover the wire armatures of the Alebrijes with a window screen/mesh

Vocabulary

sphere- a volumetric figure that has the shape of a round ball

cylinder- a volumetric figure with two congruent circular faces

Materials

lightweight mesh / window screen (available at hardware stores)

duct tape (one roll per group)

scissors (at least one per group)

Activity

1. Cut a piece of mesh in a size that will wrap around the main body of the rounded form.



2. Connect the mesh with duct tape.

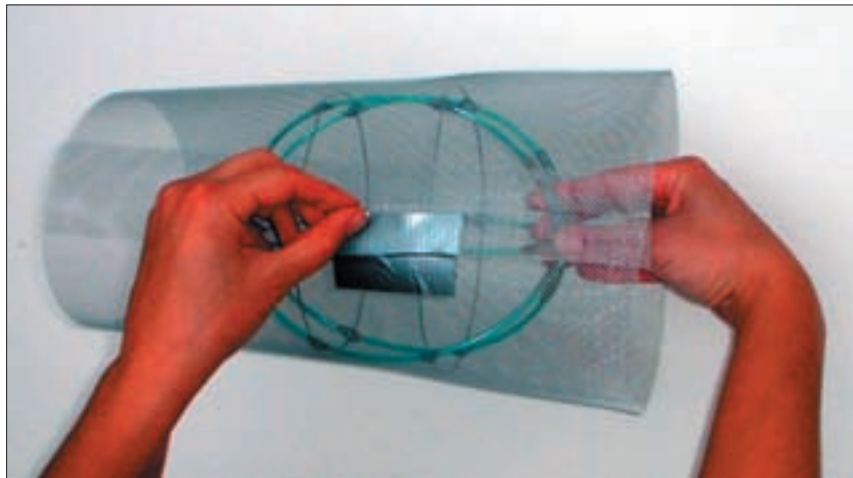

3. On one end of the mesh cylinder, cut slits into the mesh.



4. Lay down the cut pieces as flat as possible on the armature and affix with tape.

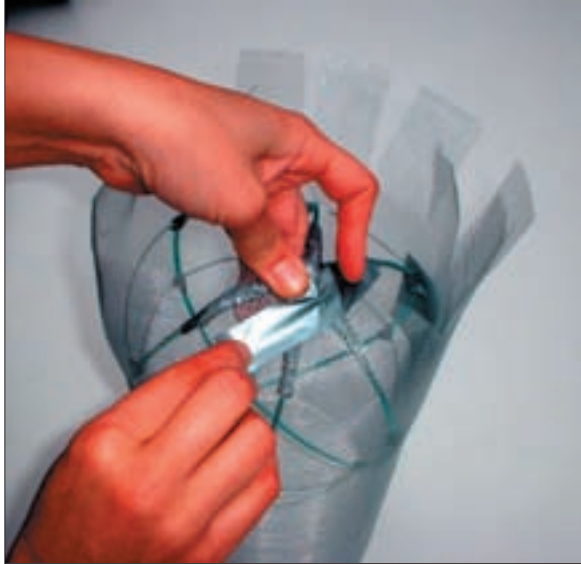

5. Make sure to leave the main joints exposed. This will make things easier when you join the body parts in a future lesson.

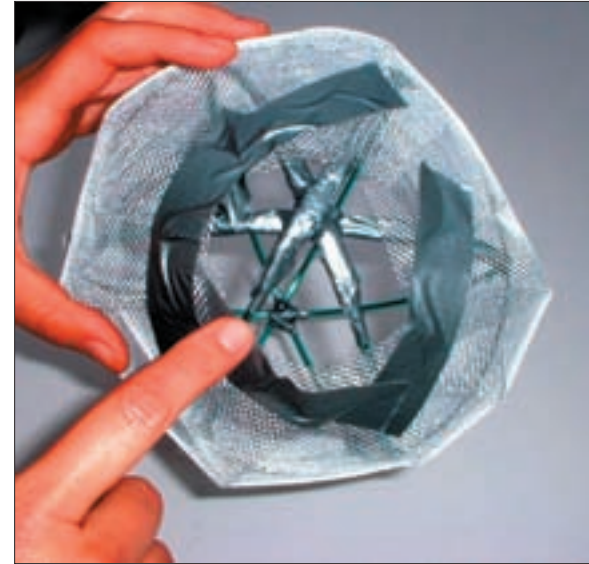

6. Once you have one side taped up, cut off any excess from the other end.

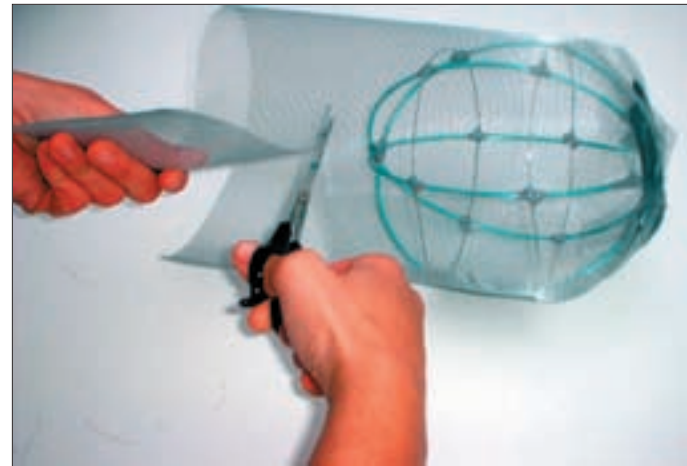

- Repeat steps #3 and #4 to tape down the mesh flaps at this end. Remember to leave this joint exposed as well. Repeat this entire process for all rounded armatures. Below is an example of a mesh-wrapped head and body figure.

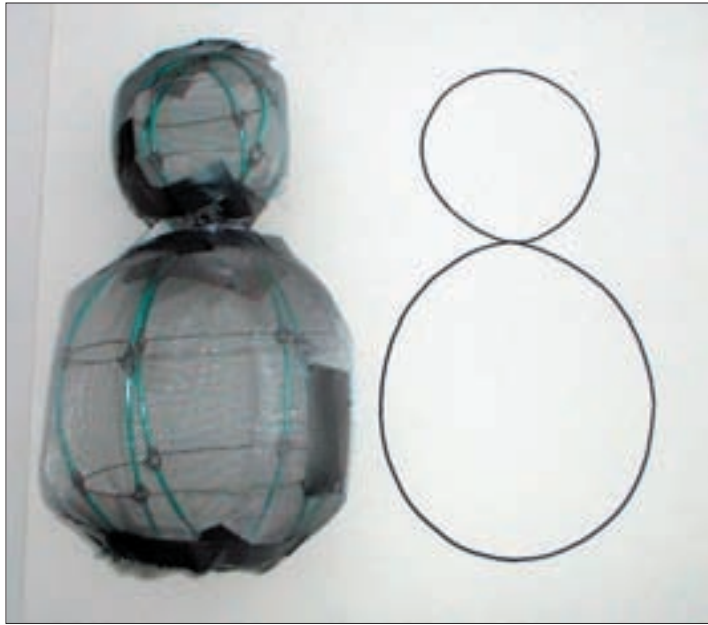

Tips to remember:

- The mesh or window screen can have sharp edges. Use caution when cutting and handling the edges!

Wings, Legs, Arms, Hands, Feet...The Construction of Other Alebrije Parts



This lesson encourages the re-use and recycling of everyday objects into inventive surprises. Now that the main armatures of the Alebrijes are built and covered in mesh, the next step is to build the pieces that make up other body parts. For this phase of the Alebrije construction, students will use an array of found objects and materials, imaginatively combining them to form the wings, arms, legs, hands, feet, ears, and whatever else they want their Alebrije creatures to have. You can ask students to collect a variety of objects that would be useful for this part of the project. Make sure they check with someone at home to ensure that they are dispensable materials! This is an inventive and exciting use of recycled materials and other objects that might otherwise be destined for the trash.

Skill
recycling materials, inventing in three dimensions

Objective
To create Alebrije parts from recyclable materials

Vocabulary
recycle- to reuse something

Materials
recycled materials including but not exclusive to:
soda pop cans, juice cans, water bottles, cardboard tubes, rubber gloves, chunks of styrofoam, cardboard boxes, foam material
duct tape (at least one roll per group)
scissors (at least one per group)

Activity

Every group we worked with wanted their Alebrije to have wings. The process for the wings is simple:

1. Draw out the size and shape of the wing desired onto cardboard
2. Cut out the wings.
3. Cut a length of the thick wire long enough to wrap around the perimeter of the cardboard wing.
4. Use the duct tape to attach the wire to the cardboard.



wing example

Your wings are ready!! For small wings, the wire is not necessary. The wire is used for extra support.

The following examples show how students used a core group of materials to form different body parts. Often, the same material can be used in many different ways. Notice, for example, how the water bottles become parts of legs, knees, arms, and eyes!



Maria and Anna's arms were made from water bottles, paper towel tubes, and duct tape. Notice that the elbow joint was made from one of the egg holders of an egg carton.



Maria and Anna made legs by taping whole and half bottles together with cardboard.

The adults leading the Alebrije project also went through the process of making an Alebrije. For the three pairs of legs we used a combination of juice cans, long and short pieces of cut styrofoam, water bottles, and tape. Notice that the tops of the water bottles that had been cut off for the legs were used on the head as bulging eyes.



The adults' sample Alebrije made use of bottles, cans, and styrofoam.

This picture of an Alebrije at a more advanced stage shows two kinds of legs: the back legs are formed by taping soda pop cans to the main body. The front legs come from molding cardboard into a cone shape.



Gloria and Laura used juice cans and cardboard to create the short legs of their Alebrije

Tips to remember:

- You can never have enough duct tape! Use it liberally to make sure that things stay firmly in place.
- Remember that the possibilities are limitless! Students can be incredibly inventive with how their found objects become parts of their Alebrije! One group made hands by stuffing styrofoam pieces and foam into rubber gloves!

Putting it All Together



In this lesson you and your students will connect the major body segments of the Alebrijes. These include the armatures of the bodies and heads you have made. But there also will be legs, arms, or other major body parts made from the recycled materials. Attachments are made in two ways: by threading wire and by taping. Sometimes you will use these techniques in combination to ensure the strength of your Alebrijes.

For the most part, the steps in this lesson are done prior to the next two lessons that involve paper macheing the entire Alebrije. However, there are some body parts that we suggest NOT attaching at this point. For example, we found that with the wings, especially if they were a large part of the Alebrije, it was easier to papier maché them almost entirely first and later attach them to the Alebrije body. This also allows for more people to work on one creature at a time. We therefore suggest not attaching wings until lesson #11: Final Attachments.

Skill
motor skills

Objective
To connect the major pieces of the Alebrijes.

Materials
lightweight wire
duct tape (one roll per group)
scissors (at least one per group)
pliers (at least one per group)
wire cutters (teacher use only)

Activity

Attaching with wire

The following example is useful for attaching any two mesh-covered wire armatures:

1. Cut and thread a long piece of thin wire through the exposed joint in the head armature. Make sure to tie it and wrap it several times around the taped up joint. You may find the pliers useful at this point to maneuver the wire.



2. Once it is firmly attached to the head, thread the wire through the exposed joint of the mesh covered body armature. Thread it through a couple of times. Pliers may also be useful here.



3. Pull the wire tightly, bringing the head and body together. You can wrap the extra wire around the neck to create a strong joint.



4. For extra support, connect the head and body at the joint with strips of duct tape. Make sure to press the tape into the crevice where the head and body connect.



Attaching with tape

Some Alebrije part connections will require only taping. For example, in the Alebrije made by the U of M students, the juice cans and Styrofoam would have been very difficult to thread wire through. Therefore, the legs and tail were all joined to the body exclusively with duct tape, as shown below:



Tips to remember:

- Always turn wire ends in so that there is no danger of them poking anyone!

Make Your Own Glue: A Recipe For Papier-maché Paste / Engrudo



Soon you will be covering the mesh-covered armatures with papier-maché. In this lesson you will learn to make the homemade paste for the papier-maché process. This glue, called “engrudo” in Spanish, is the same paste used to make piñatas.

This lesson consists of a quick and fun demonstration and measuring exercise. Everyone takes a turn measuring, pouring, and stirring the flour and water that make up the engrudo paste. We found the students quite enthralled in the hands-on demonstration. Then we broke down into our smaller groups to repeat the process, giving every student an opportunity to have a hand in every step.

Making the paste involves use of a hot plate or burner. For safety purposes and to maximize class time, we suggest mixing/cooking a big batch of engrudo paste and bringing it in for use after students have prepared the raw ingredients in class. This means that the materials students mix in class is not actually used to begin papier-machéing.

We suggest combining this lesson with the next lesson “Putting on the Paper Maché,” using the pre-prepared engrudo paste that you bring to class.

Skill

liquid measurement in milliliters (mL), estimation, proportions

Objective

Students will measure and mix raw ingredients to create a glue ideal for papier machéing.

Vocabulary

mL- a unit of liquid measurement

estimate- an approximate calculation

about- reasonably close to, approximately

proportion- the relation of one part to another or to the whole

papier-maché paste- a strong homemade glue made from cooked flour and water

engrudo- Spanish word for papier-maché paste

Materials

2 containers (per group) with delineated lines for metric liquid measurement (plastic spray bottles can be cut with scissors for a safe measuring device)

1 container (per group) for combining raw materials water (measure accordingly depending on number of students or groups)

flour (1 large bag is plenty for the class)

spoons (one for each group)

Activity

Part I: Demonstration

1. Lay down newspaper or a plastic covering to protect the floor; and have everyone gather in a circle.
2. Measure out about 140 ml flour into a container



Gloria measures out flour

3. Measure out about 1000 ml water in another container



Gino determines if the correct ml amount has been reached

4. In a third container mix all of the flour with a small amount of the water to make a soupy liquid.



Carlos begins to pour some of the water

5. Once this mixture is combined with no lumps, add the rest of the water to the flour/water mixture and stir.



Angel mixes the flour/water combination as Gino and Carlos look on

After completing the measuring and mixing, explain that the combined flour and water paste gets cooked quickly over high heat for several minutes with constant stirring. Show students the cooked engrudo paste you bring in so they can observe the difference in consistency between the raw flour/water mixture and the engrudo paste it becomes once it is cooked. When this is finished, break up into small groups for the next stage of the activity.

Part II: Small Group Work

At the end of this lesson you will find the recipe for the engrudo paste printed in both English and Spanish. You can photocopy and pass this out to each member of the class or each group so everyone has a recipe to follow during the small group work session. In the small groups, students will repeat what was done collectively in the class demonstration, giving each person more hands-on opportunity to measure, combine, and stir. (Step #4 is written into the recipe in the event that students wish to try the recipe at home under close supervision by an adult.)

For small group work, a smaller proportion of water and flour can be used to minimize the bulk of the raw water/flour mixture to be prepared. A little bit goes a long way! The proportions for pair work can be 350 ml water and 50 ml flour.

Remember that the raw materials combined in the small groups will not be used this day to papier-maché. You can cook this raw material for use on another day or dispose of it accordingly.

Follow-up Discussion

After students have worked in small groups, you can bring the class back together to discuss the experience. Below are some questions you can discuss as a group.

- About how much more water than flour is there in the recipe?
- About how many spoonfuls is 50ml of flour?
- Why do you think it's ok to measure out the ingredients only approximately?
- For what kinds of mixing would you need ingredients to be EXACTLY measured?
- For what kinds of mixing can ingredients be approximated or estimated?



Gino uses math to calculate liquid measurements

Tips to remember:

- The engrudo paste should be kept refrigerated when not in use. A batch of paste can be used for several consecutive days if refrigerated properly. If the paste begins to spoil it should be discarded and a new batch prepared.

Recipe For Flour & Water Paste: Engrudo For Papier-maché Alebrijes

Ingredients:

about 50 ml flour

about 350 ml cold water

1. Measure out about 50 ml flour in one container and 350 ml water in another container.
2. In a pot mix all of the flour with a little bit of the water, enough to make a thick soupy liquid.
3. Add the rest of the water to this mixture and stir. Make sure to blend in the flour completely. The less clumps the better!
4. Heat the mixture on a high temperature on the stove top, stirring constantly. Make sure nothing sticks to the bottom of the pot. Little by little the paste will gradually thicken over the heat. Once it starts to bubble, remove from heat. Cool before using.

Receta para Engrudo para el papel maché de los Alebrijes

Ingredientes:

aproximadamente 50 ml de harina

aproximadamente 350 ml de agua fría

1. Mide aproximadamente 50 ml de harina en un recipiente y 350 ml de agua en otro recipiente.
2. En una olla, mezcla todo el harina con un poquito de agua hasta hacer un líquido espeso.
3. Agrega el resto del agua a esta mezcla y revuelve todo junto. Mézclalo muy bien hasta que se quede liso, sin pedacitos de harina.
4. Calienta la mezcla sobre la estufa a una temperatura alta, mezclando constantemente. Ten cuidado que nada se pegue a la olla. Poco a poco el engrudo se convertirá mas espeso a calentarse. Cuando empieza a burbujear quita la olla de la estufa. Deja que el engrudo se enfrie un poco antes de usarlo.

Lesson 10 Putting On the Papier-maché



In this lesson students will cover the mesh-covered armatures as well as other large Alebrije parts with papier-maché. As the wire formed the skeletal structure of the Alebrijes, the papier-maché covering forms the ‘skin.’ Paper is a strong material that helps bind all of the parts together and forms a surface on which to paint the patterns and designs of the Alebrijes.

The more layers of papier-maché you have covering the Alebrije structures, the stronger they will be. We suggest putting down at least two layers, and more if you have time. Also, if you have more than one teacher and can put down a layer yourself this can further ensure its strength. We did this only after making sure that the students had taken full part in the process themselves. In general, we did not do any work for the students that they themselves did not participate in.

Skill
motor skills

Objective
To cover the Alebrijes and Alebrije parts in papier-maché to create the ‘skin’ of the creatures.

Vocabulary
about- reasonably close to, approximately

Materials
papier-maché paste/engrudo
bowls (at least 1, preferably 2 for each group)
brown paper bags (recycled from the supermarket)

Activity

1. Rip the supermarket brown bags in halves or quarters, into a manageable size.
2. Have students dip these ripped papers in water and then crumple them with their hands. They can un-crumple and re-crumple the papers, to get them as wrinkled and pliable as possible. We do this so that the papers become soft and flexible. They adhere much better to the mesh and to each other this way.
3. Have them rip the papers into long strips, about 7cm wide. For large areas to be covered the strips can be larger, for small areas they will need to be smaller.
4. Smear the paste onto both sides of the brown paper, making sure it gets wet but is not overloaded with the paste. Smooth away any clumps.
5. Lay it onto the mesh covered Alebrije part.
6. Smear the paste onto another strip of wrinkled paper and lay it onto the mesh as well, overlapping this new piece slightly with the piece previously placed. Repeat this process until the entire alebrije is covered.

When papier-machéing over rounded forms: follow the same process as when you cut the flat mesh to fit over the rounded forms: tear the paper so that it will better fit over the form. Use as many tears as necessary to achieve the smoothest surface possible.



In areas where there are two rounded forms connected (a head and body, for example), make sure to get the paper into the crevices where parts such as these connect.



Some students can work on the large mesh covered body parts. Others can papier-maché the wings or other small parts that will later be attached to the main body.

Make sure to not papier-maché any areas where there will be a joint or attachment. These joints will get paper mached later.

Tips to remember:

- The first layer of paper is the most difficult to apply. By overlapping the papers as you lay them down, you can work your way around the entire form bit by bit until the first layer is complete.
- In subsequent layers, criss-cross and overlap the papers in all different ways. Use long pieces that wrap smoothly around body parts to ensure the overall strength of the Alebrijes.
- Use a moderate amount of engrudo, making sure there are no big chunks of paste trapped between layers or between the mesh and first layer!

Lesson 11

Final Attachments and Papier-Maché



This lesson is listed separately in the event that the Alebrijes in your group were especially complex and required extra technical guidance. Now it's time to add wings, tails, tusks, ears, or any body parts that were paper mached separately. The following process repeats the steps in lesson #8: Putting it All Together.

Skill
motor skills

Objective
To complete final attachments and the final papier-maché process prior to painting the Alebrijes.

Materials
lightweight wire
duct tape (one roll per group)
engrudo paste
bowls (at least one, preferably two for each group)
brown paper bags
wire cutters (for teacher use only)

Activity

1. Depending on the appendage and its function in the overall stability of the Alebrije, you can attach the final parts in one of two ways:
 - a) **with wire and duct tape** (better for larger attachments or for those that play a role in the overall stability of the Alebrije. For example: spindly legs, larger wings, elaborate tails, etc.)
 - b) **with duct tape only** (fine for small or light attachments such as ears, tusks, small wings, tiny tails, short legs that are not major stabilizing factors, etc.)

Hopefully the areas close to the points of connection were left without paper mache covering. It is at this point that you attach the appendages with wire and/or tape.



Gloria, Laura, and Jenny made legs out of soda cans and cardboard cones and attached them with duct tape.



2. Papier-maché at least two layers over all of these final points of attachment. It is especially important that you apply long strips of papers that criss-cross and use the paper to connect body parts that have been previously connected with wire and tape. Make sure to cover all of the duct tape. The entire Alebrije should be covered in brown paper.



Angel/Carlos/Gino/Andres/Meghan's Alebrije with its wings, legs, and horns attached and stable.

Tips to remember:

- Be careful that the final body parts, once attached and papier maché

Lesson 12 Patterns Through Movement



Anna, Maria, and Molly begin their pattern sequence based on their original symbols

All of the Alebrijes that Don Pedro Linares saw in his visions had something in common: bold, brilliant, colorful patterns covered their bodies. The patterns were made up of both simple and intricate markings and designs. We wanted to get the students excited about possibilities for painting and pattern making. We decided to warm up to the task of making patterns and sequences for painting with a collective movement exercise done outdoors. Our students LOVED this activity, as they did with everything that involved movement, and even more so when they got to go outside.

We gathered in a large circle to do a very physical exercise that involved translating movements into marks and rhythms with colored chalk on the ground. Then we broke up into smaller groups to expand on what we had done. One adult leader for each small group is helpful.

Skill

pattern creation, group work

Objective

To understand and make visual patterns through a movement game and chalk drawings

Vocabulary

pattern- an artistic design or arrangement of parts which contains repeated elements

symbol- a visual image that stands for something; a shape or picture that represents a thing or idea

Materials

chalk in a variety of colors

Activity

Part I: Group Movement Exercise

Go outside onto the concrete and have everyone get into a circle. Each person should have a piece of colored chalk.

1. The first person says their name and makes a movement of their favorite sport. (You can choose whatever theme you wish.) Everyone tries to guess what the sport is.

For example, Angel says his name, then moves his arm forward like a quarterback throwing a ball. Everyone guesses that Angel loves football.

2. After the group guesses, the person draws a symbol or picture that represents the movement of their favorite sport on the ground in front of them.
3. Everyone repeats Angel's name and movement.

4. The next person says their name and shows their favorite sport through movement. Then the entire group repeats both the first and second persons' names and movements. Repeat this process until everyone has had a turn.

After several people the exercise might look something like this:



Maria's symbol for dribbling a basketball, Anna's symbol for feet that will kick a soccer ball, and Molly's symbol for a swimmer's arms in motion



Gino and Anna mark their symbols on the ground in front of them.

Some people chose to be purely symbolic, others were more representational, and still others combined both symbol and picture.

Part II: Making patterns with the symbols and markings

In smaller groups we continued doing pattern games based on the movements and symbols we had just created.

Gino, Carlos, and Angel made up a fast paced drawing game. They took turns writing their symbols one after another along the entire length of the curved white line of the basketball court. They did this several times, each time varying the order in which they took turns and the number of times each person made their mark. Each sequence produced a distinct pattern which we made sure to observe.

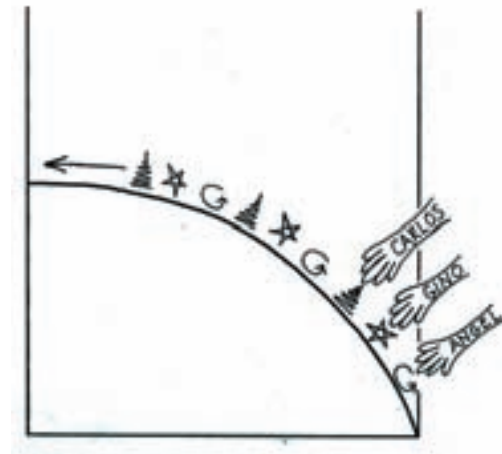

Anna, Maria, and Molly took a different approach. Each drew their symbol in a determined order in a straight line. Then, standing side by side, they walked forward all together. As they passed each symbol on the ground, they all made the movement each symbol represented. They moved fluidly from one movement into another, not stopping in between. From a distance, it looked like a dance. This could be done several times, making a variety of 'dances.'

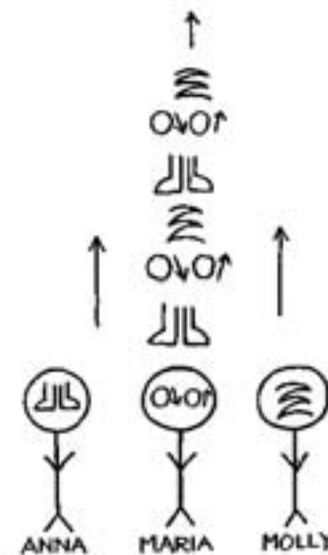

Lesson 13 PaTtErNs, PaTtErNs, & more PaTtErNs!



A class session spent making collaborative patterns on large sheets of paper is a good way to get students focused back onto the Alebrijes and the kinds of patterns they may want to paint on them.

You can spend the first part of class showing images of patterns. Diverse patterns from a variety of world cultures are great visual inspirations for this lesson. The book suggested in this lesson would serve this purpose, or any pattern books or textiles of your own choosing would also be useful to inspire the students in preparation for their Alebrije painting.

Skill
pattern making and pattern recognition

Objective
To practice pattern making and sequencing; to brainstorm ideas for the painting of the Alebrijes.

Vocabulary
pattern- an artistic design or arrangement of parts which contains repeated elements

Materials
large papers in an assortment of colors
markers or crayons

Visual References
Studio Design Patterns for the 21st Century by Akio Fukuda
textiles, wrapping paper, or any books of patterns



an example of collaborative pattern making

Discussion

As a class, look at selected images from books or textiles to see all the patterns students can identify. The purpose of this is to get students thinking about the kinds of elements that patterns can be composed of, including shapes and color. We also wanted to get them thinking of how artists can organize shapes and colors to make patterns and slight variations using similar elements. The following questions may be helpful for students in guiding their observations.

- What are some of the repeated elements in this pattern?
- Is there more than one pattern going on in the same picture?
What are they?
- How many colors does the artist use in the pattern?
- Are there any patterns in which the shapes and the colors change?
- How are similar shapes turned or flipped to give variation to a pattern?

After looking at the patterns and noting observations, students will break up into their groups to begin making patterns of their own.

Activity

1. Each person in the small groups can contribute a number of symbols, shapes, or simple designs that they like to a collective brainstorming page.
2. On a large piece of paper, have students take turns making simple patterns based on the shapes, lines, or other elements they have created. Students can make a variety of collaborative patterns together, beginning with simple ones as a warm up and getting more complex as they continue. If time permits, students can also make pages of their own patterns and designs.



Notice how colors can play a role in the patterns



If this happens, look for the patterns in the chaos!

Lesson 14 Painting the Alebrijes!



By now students are eager to get to the final and very rewarding part of the Alebrije project: the painting!!

Our students were a diverse group with regards to their methods. One group engaged in careful diplomatic decisions. This particular group was quite methodical, sketching out lines and designating certain color choices in pencil prior to painting. Another group was extremely fast paced and each person seemed to paint whatever and wherever they wanted on the Alebrije. This process worked great for this particular combination of individuals. We did stress, however, that everyone had to be respectful of each others' work.

Whether the painting process is methodical, random, or a little of both, we suggest that each group work with its own dynamic energy, maintaining respect for everyone's work and contributions to the whole. If the spirit of each group guides the artists and their process, then the painted Alebrijes will most likely reflect the spirit and energy of their makers.

Skill

color mixing, proportions

Objective

To mix acrylic paints and paint the Alebrijes with patterns of bold colors and designs.

Vocabulary

about- reasonably close to; approximately

Materials

acrylic paints: at least the primary colors (red/blue/yellow), white, & black
brushes: large for big areas, small for detail areas
drop cloth (to cover the floor)
tape (to secure the drop cloth to the floor)
newspapers (to cover the desks)
water in small buckets for cleaning brushes
paint palettes (1/person; paper plates work well if you don't have washable recyclable materials)

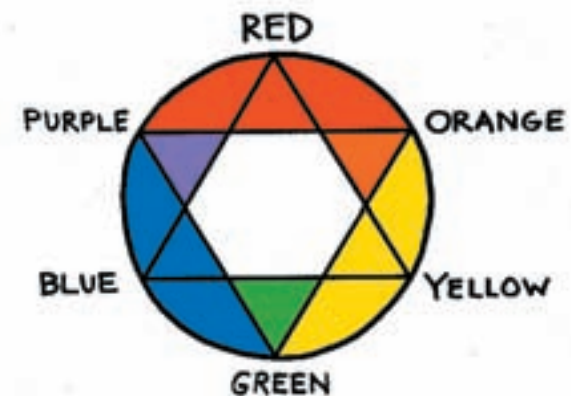

Activity

1. Each group should paint their Alebrije entirely white so that when the colors are painted on they are as bold and brilliant as the true paint color. One layer should be sufficient. Let the white coat dry before beginning the actual patterns.



Angel contemplates the Alebrije in hand.

2. Have students mix the colors they want. You can draw a color wheel on the board to guide students in their color mixing. As they mix colors, have them observe the proportions of the colors they are combining. For example, if they mix a bright green, how much yellow did they use in comparison to the amount of blue?
3. Students can reference the patterns they made in the previous lesson or any pattern books on hand, for last minute ideas and inspiration.
4. PAINT!! We encouraged our students to be inventive and imaginative even though they didn't seem to need our advice in this realm! Their imaginations, like Metric Arts, ruled!

Tips for painting:

- We encouraged people to start with the big parts of the designs and work in towards the details. It was much easier to put a base coat and paint the details over that color than to do the reverse.



Anna concentrates



Maria, Anna, and Molly apply base coats of color to their Alebrije



Gino, Angel, Andres, and Carlos begin applying color



Gloria and Laura work on the wings



Gino paints face to face with a head of the Alebrije



Carlos and Angel concentrate on their work



Anna, Maria, and Erica paint away



Gloria applies a polka dot pattern



The three-headed Alebrije comes to life



Angel, Carlos, and Gino's Alebrije

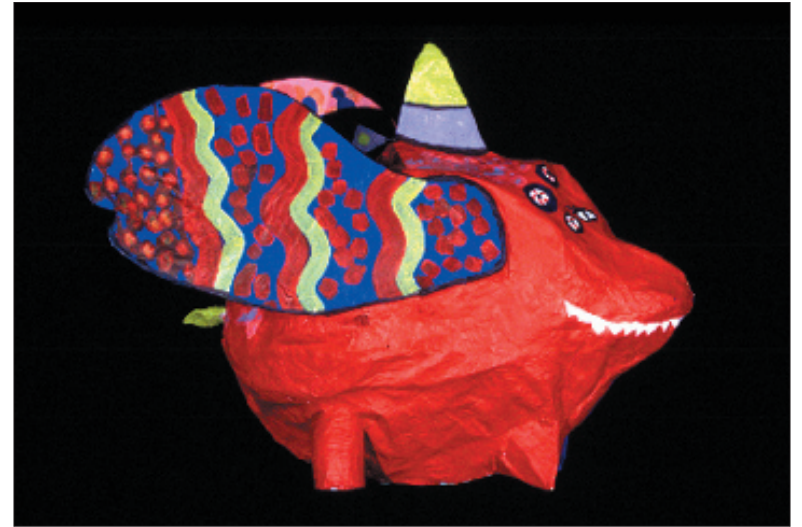

Laura and Gloria's Alebrije



Angel, Carlos, and Gino's Alebrije detail



Laura and Gloria's Alebrije



Maria and Anna's alebrije



Maria and Anna's alebrije (back view)



An alebrije from Oaxaca and Maria and Anna's alebrije: kindered spirits!

A Conclusion to Alebrijes...

We have come a long way from the original sharing of the Alebrije story to the completion of these wonderful Alebrijes! Everyone did such a wonderful job! There are lots of places you could go from here now that you know this technique - making puppets, masks, or things that we haven't even dreamt of. And as Don Pedro Linares showed, even dreams can become real!





An Introduction to Bookmaking...

In the Bookmaking project, each child makes a book that is about their hopes and dreams for the future. The bulk of the project is actually about the construction of the book as an object—its size, shape, cover and page layouts. All of these design decisions are a chance for each child to express an aesthetic preference and to create a representation of their identity. At the same time, almost every step of the process requires skill in metric measurement. The book is constructed so that pages of writing and art can be added at any time. In the end, the book becomes a container for content and further exploration.

We began this project by exploring how symbols are made. This was followed by a study of a variety of children's books, giving students a chance to express their preferences about the books' interior and exterior design. With this background, students set upon the task of choosing a shape for the cover of their book, a shape that would be a symbol of what they might want to be when they grow up. The challenge was to choose a shape or symbol that would best communicate the content of the book they were about to make. How would the external shape function as a symbol to reveal clues about the contents inside? We often took breaks from the technical work of book construction to do more open-ended and imaginative projects about the desired content—the dreams and visions that students have for themselves. We did not include these projects in this guide because we did not want to disrupt the continuity of the construction process. However, these additional exercises, which also included metric measurement skills and math concepts, will be documented in the next curriculum guide. In the meantime, we hope that you will invent your own art and writing projects to fill the pages of the book.

We had a very favorable student to teacher ratio, which allowed us to use heavy materials for the book covers. These book covers could only be cut out with razor blades, which were not permissible for use by the children. Consequently, some of the work had to be done by the college students outside of our time with the Harms students. You can decrease this preparation time by using lighter weight materials. We make notes of such instances under the Variation heading in the various lessons of this section.

LESSON 1

Symbolize Your Movement: movement, line, pattern, shape, and symbol



We use symbols all the time in our daily lives. Words and letters are symbols. Traffic and transportation signs are a kind of symbol. In art we create images which are symbols for feelings, ideas, and things. For example, many people think of the dove as a symbol of peace.

Symbols are formed in a variety of ways. This lesson practices one of the many ways in which symbols can be made. We begin with movement, the originating action that leads us through the transition to rhythmic lines, to patterns, to shapes, and finally to symbols. We found that movement exercises help activate the energies and ideas of our students, incorporating their bodies and thoughts. All of the steps involve creations and choices of the students' making, so they are invested in the entire process.

During this activity, you can ask students to work on the board if you have one so that students can share what they are doing. To maximize time, several people can go to the board at the same time, or each person could also work at their desk on a piece of paper while you lead a demonstration of this process from the board. You can structure the method depending upon your time constraints.

If you have time, we highly recommend devoting a class to a group reading of The Book of Rhythms by Langston Hughes. It embodies a wonderfully holistic approach to the theme of this lesson from the most seemingly small to the most universal concepts that involve the making of movements, rhythms, lines, patterns, shapes, and symbols.

Skill

Visual thinking using symbols

Objective

To create personal symbols from rhythmic line, pattern, and shape

Vocabulary

movement- an action of the body or limbs made to express or emphasize an idea, sentiment or attitude.

rhythm- a movement, sound, or visual element in which some action recurs regularly.

line- the path of a moving point.

pattern- an artistic design or arrangement of parts which contains repeated elements.

shape- a 2-dimensional area of space bounded on all sides.

symbol- a visual image that stands for something; a shape or picture that represents a thing or idea

Materials

white paper
colored poster board
pencils
crayons
scissors

Visual References

The Book of Rhythms by Langston Hughes

Activity

Making movement:

1. Students sit in a circle.
2. Each person thinks of their favorite animal. Taking turns, have each student express through the movement of their hands and/or body a motion that their favorite animal makes.

Students will often want to make more than one motion for their animal. We suggest that you encourage them to explore as many possibilities as you have time for. It can be fun for the students to make the motion(s) and have the rest of the class guess what their animal is.



Gino's favorite animal is a snake. He moves his hand in a side to side wavy fashion to show the path that the snake travels.

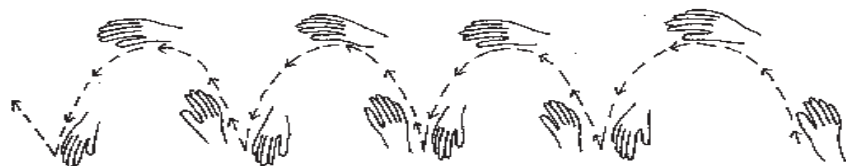

Janie's favorite animal is a bunny. She moves her hand in a motion that imitates the hops a bunny makes.

Turning movement into a rhythmic line:

Students have just made movements through the air that represent a specific animal. These repeated movements create a rhythm.

3. Each person goes up to the board with a piece of chalk and repeats one chosen movement several times with the chalk in their hand.
4. Each person turns to the board and makes the movement with the chalk touching the board. This turns their movement through the air into a moving line that can be seen on the board. When students lift the chalk off the board as they finish, the rhythm of the chalk on the board will reflect the rhythm of their hand in motion. They have turned their movement into a rhythmic line.



Gino draws out the wavy line that reflects the movement his hand made. His line reflects the movement of the snake and also the form of the snake itself.



Janie draws out the curves and points that reflect the movement her hand has made. Janie's line reflects the movement of the bunny, not the form of the bunny itself.

Turning rhythmic line into pattern:

Now each student has a line that is their own movement, like no one else's.

5. Have each student repeat their rhythmic line on a piece of paper. Have them do this several times to create a pattern of lines on their paper:

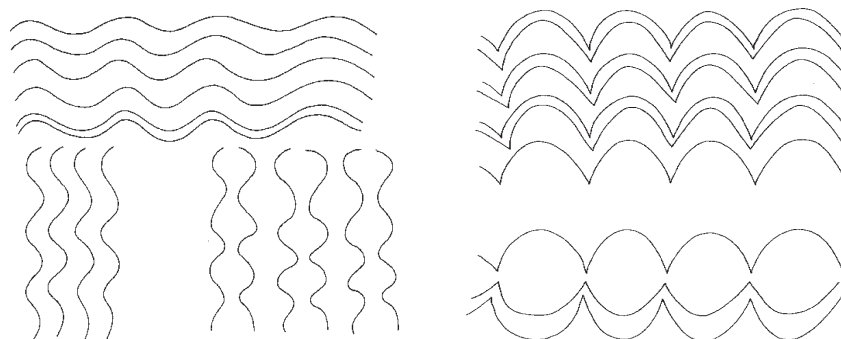

You may want to ask students what a pattern is, where they see repeating elements in everyday life. For example, you may want to have them point out patterns that exist in the classroom or on their clothing.

Turning pattern into shape:

Now each student has a series of rhythmic lines on their page and have created a pattern.

6. Each student explores how many different shapes can be formed from the patterns of lines they have created. Encourage them to connect their pattern lines in as many ways as they can think of, and to close off the lines to make shapes that are bounded on all sides. Have students color in the shapes they have created.



Gino and Janie's lines become shapes.

Turning shape into symbol:

7. Each student chooses a shape or a piece of a shape to become their symbol.



Gino's favorite shape was a wavy shape that extends across the page. As a symbol it stands for the way a snake moves, or for the snake itself.



Janie's choice was a combination of two shapes that include the rounded curves of the bunny's hop. It represents the motions a bunny can make.

Have students redraw the part of their shape they want as their symbol on poster board and have them cut it out. The symbols can be hung in the class with each person's name on it as a lesson and concept to refer to throughout the bookmaking process.

To create further art projects from this lesson you can cut and trace the symbols multiple times and:

- make a collage
- make a design of repeating patterns

Ideas for Follow-up Discussion:

Following the exercise, you may want to have a discussion with students about the process they have undergone, or a conversation relating to symbols in the world in general. Stress that there are no wrong answers or ideas. If a student has reasons or feelings for why a certain symbol is associated with a certain idea or belief, then it is a symbol for them. The same symbol can mean different things across cultures. The purpose of this discussion is to get students thinking about what kinds of signs or symbols they associate with certain things and ideas and why. The following are some suggestions for discussions.

1. Discuss with students how each of their symbols represents their animal. For example, how did Gino's symbol represent a snake? How did Janie's represent a bunny? Why did each person choose the animal they did? What might the animal as a symbol itself represent?
2. Have a general discussion with students about symbols in the world. Some questions to guide them might be:
 - Where do we see symbols in our everyday lives? Name as many as you can.
 - Can colors be symbols? How? What can different colors represent?
 - Can you think of ways in which symbols function as instructions or directions?
 - Why do you think symbols are pictures and not words?
3. Symbols can stand for things or for ideas. You can do an exercise with students to explore symbols as ideas, again using animals:
 - What can a lion be a symbol of? Why?
 - What can a dove be a symbol of? Why?
 - What can a dog be a symbol of? Why?

or:

- The idea is “bravery.” What animal could be a symbol for this idea?
Why?
- The idea is “peace.” What animal can be a symbol for this idea?
Why?
- The idea is “loyalty.” What animal can be a symbol for this idea?
Why?

In the same spirit, you might analyze how a symbol could stand for both a thing and an idea:

- What can a circle be a symbol for?
clock (thing) and time (idea)

4. Have a discussion based on street signs/symbols. Have a variety of the traffic/people figures to show as examples:



What Do You Love About Books?



The purpose of this activity is to fuel students' excitement about books and reading in anticipation of their own bookmaking. We worked in groups, looking at the pictures and reading through the books, sharing them among the small groups. This simple and fun exercise consisted mainly of observation and conversation about what the students liked, what they thought worked well, and what might have been different. We found that it was beneficial for our students to look at a variety of books and make note of what they found exciting and inventive, as a way to get their ideas flowing for their own books.

The books we used, listed here under "Visual References" were selected with attention to the cultural and linguistic diversity of our group. Use any books that you feel are appropriate for your group and suggest that students bring in some of their favorite books to share.

Skill

Group interaction, sharing, observation, articulation of thoughts and preferences

Objective

To find inspiration and ideas for the students' books.

Materials

pencils
paper

Visual References

A variety of books for students to look at in pairs or in small groups. Below are a list of books with colorful words and images from a diverse array of cultures:

The African Dream: Visions of Love and Sorrow: The Art of John Muafangejo, by Orde Levinson

A sembrar sopa de verduras, Lois Ehlert

The Big Box, by Toni Morrison with Slade Morrison, Illustrated by Giselle Potter

HARLEM, by Walter Dean Myers, Illustrated by Christopher Myers

The Hippo Hop, by Christine Loomis, Illustrated by Nadine Bernard Westcott

Huichol Indian Sacred Rituals, by Susana Eger Valadez, Images by Mariano Valadez

Gathering the Sun, An Alphabet in Spanish and English, by Alma Flor Ada, Illustrated by Simon Silva

LIFE Doesn't Frighten ME, poem by Maya Angelou, Paintings by Jean-Michel Basquiat

lizards, frogs, and polliwogs, poems and paintings by Douglas Florian

MOLA: Cuna Life Stories and Art, Maricel E. Presilla

The Story of Colors/La Historia de Colores by Subcomandante Marcos,
Illustrated by Domitilia Dominguez

The Tree is Older Than You Are: A Bilingual Gathering of Poems and Stories from Mexico, selected by Naomi Shihab Nye, paintings by various Mexican Artists

Wadsworth Jarrell: The Artist as Revolutionary, by Robert L. Douglas

Willy el Sonador, by Anthony Browne

Wirrimanu: Aboriginal Art from the Balgo Hills, by James Cowan



Activity

Have students work in pairs or in small groups, depending on the number of books available and how you wish to organize your class. Following is a list of questions that the students can be asked to consider while they are looking at a variety of authors' and illustrators' words and pictures. Encourage them to make notes as they explore.

Questions

- What do you like most about the pictures? Are they colorful? Are they all over the pages? Are they contained in certain areas?
- What do you like most about the writing? Is it combined with the pictures? Is it separate? Do you notice anything special about the way words are arranged?
- Are there borders on the pages in these books? Why do you think they're there? Do they work well?
- Does a certain book have elements that you would like your book to have? What are they?
- What makes you love a book and want to read/look at it all the time?

Have students make notes of their observations and thoughts, either in class or for a homework assignment having them reflect on what they observed and talked about.

Mobilize Your Vision!



This three part lesson includes a group movement exercise, a discussion, and an activity. It is designed to encourage students and teacher(s) to share their ideas and visions of themselves. This lesson relies heavily on concepts from Lesson 1 “Symbolize Your Movement.”

We often did group work as a way to build group unity, develop a class spirit in a common goal, and facilitate the unleashing of the students’ imagination through collaboration. Using our entire bodies in often fun and humorous ways also facilitated the students’ ability to remember their classmates’ shared thoughts and visions.

We found several of the students to be brimming with ideas, but at times very hesitant to share them within the larger group. As always, patience and encouragement were our first priority. Oftentimes, if a student did not want to share they would ‘pass.’ Always they would eventually share their thoughts upon seeing that others volunteered their suggestions. Other times students were in doubt as to how to express their ideas through motion. The group would help come up with suggestions and the person would choose the idea they liked best or else would be inspired to come up with a motion on their own.

Skill

Speaking in front of a group, collaborative work

Objective

To create collaborative collages using shapes, symbols, and drawings that express multiple visions.

Vocabulary

collage- a design or picture made by gluing paper and other materials onto a surface

Materials

- construction paper
- drawing paper
- scissors
- crayons
- pencils
- glue sticks

Activity

Part I: Group Movement Exercise

1. Students sit in a circle.
2. The first student says their name and something they would like to be when they grow up. They also create a motion that describes their choice. For example, Maria wants to be a teacher. She describes her choice by raising up her hand and making a squiggling motion that describes writing something on a black board.



3. All the students in unison repeat Maria's name and then, while doing her movement, say the word that describes who/what she wants to be.

For example, when it came to Maria, we all repeated together in unison: "Maria, Teacher;" while making a squiggling motion with our hands.

4. The next student, Joe, introduces himself and says his vision for himself and does a motion.

5. As a group, everyone repeats Maria's name/vision/motion as well as Joe's name/vision/motion.

6. Repeat this process (each time beginning with the first person in the circle and ending with the most recent participant) until everyone has had a turn, and all students have completed saying the full circle of names, visions, and motions.

For example, a sampling of this exercise could be something like this:
- "Maria. Teacher." (as we all made a squiggling motion on the imaginary board.)
- "Joe. Basketball player." (as we all made the motion of dribbling a ball.)
- "Estefania. Artist." (as we painted a picture on an imaginary canvas in front of us.)

Part II: Discussion

Now that each person has a vision and movement, talk about how a movement can turn into a shape. Use your own motion or one of the students' motions as an example to the class. Brainstorm with the class and draw the sample ideas on the board as students offer suggestions.

For example, repeat that Maria chose to represent "teacher" by moving her hand as if to make marks on the board. Maria could begin the search for her shape by drawing a squiggled line that represents this motion. This line can become a shape by repeating a second squiggled line again, just underneath the first, and then connecting the ends.



This is only one of the many ways that Maria could have made her line into a shape.

Part III: Activity

1. Have each student create a shape that represents their movement.
2. Each student draws and cuts out their shape from a piece of colored construction paper. As the students work, you may want to ask:
 - Did two people use the same shape to represent different motions?
 - Did two people with the same motion make different shapes?
3. Group students into pairs or groups of three and give each pair or grouping a large piece of paper:
4. Each group of students glues their shapes onto one paper, deciding collectively where and how the shapes should be arranged. (Some of our groups organized their shapes to stand alone on the page; others overlapped. We made clear that anything goes.)
5. Use crayons to draw on and around the collaged shapes to create a drawing that incorporates the groups' ideas.

For example, if Gloria (the archeologist) and Javier (the baseball player) were to work together on this activity; they might create a scene that involves the archeologist finding evidence of ball games of the past, inspired by their connection and by incorporating their two dreams of themselves into one image. Or they might use the baseball diamond as the structure of an archeological site. By working in pairs or small groups, situations are created where unpredictable images and ideas can be realized.

Have students share their drawings with the rest of the class.

Variation

Have each student make a drawing that shows what they want to become when they grow up. The drawing can be any one or a combination of the following:

- a picture that literally shows them being a teacher/lawyer/baseball player etc.
- objects that represent their chosen profession
- a collage of abstract symbols or patterns that represent who they want to be

Brainstorming Book Covers



This lesson builds upon the previous movement exercises in Lessons 2 and 3 “Symbolize your Movement!” and “Mobilize your Vision!” It also builds upon student observations of books and what they liked and found most interesting about them. In this lesson, the shape of each student’s book will be derived from a symbol used to represent its content. The idea is that, while we can never tell the whole contents of a book from its cover, the shape of the book cover can give a clue about what we are going to find inside. Decisions regarding book content will be derived from detailed note taking and sketches as the students further explore and document what and who they want to be.

This is a very important lesson for two reasons. On the one hand, it encourages students to explore in depth their dreams and aspirations, affirming and supporting their desires, curiosities, and endless possibilities. It is also about the process of abstracting the essential characteristics of an idea or image. In this process perception and cognition are linked in the creation of a shape (their book cover) which expresses or represents an idea that will be the content of the book.

Depending on the preparation done beforehand, this lesson may go fairly quickly. In this case, you may want to move right into the next lesson: “Building Books!”

Skill

Note taking, symbol creation

Objective

To build a personal archive of autobiographical notes and to create a book cover shape that best expresses the content of the book.

Vocabulary

content- what something is about; meaning

shape- a 2-dimensional area of space bound on all sides

Materials

pencils with erasers
blank paper for writing & sketching ideas

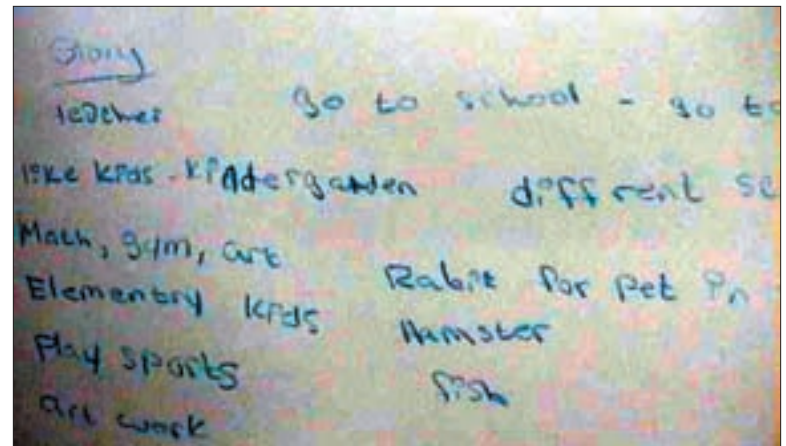

Maria's Notes

Activity

1. In small groups have students brainstorm in greater depth about their likes, visions, and dreams of who they want to become. Do this by having students list their ideas on a piece of paper:
2. Continue a discussion about the possible connections between ideas and shapes. What parts of their visions can be associated with certain shapes or forms? Have students sketch shapes on the same paper where they are recording ideas.
3. Have students choose the shape that they feel best represents their dreams and visions for themselves. This will be the shape for their book covers.

We encouraged all students to be as imaginative as possible and supported everyone's decisions as to the forms their books would take. Gloria wants to be an archeologist. She took many notes and made various sketches of pyramids, ultimately deciding that her book would take this form.



Gloria and Mr. E taking notes

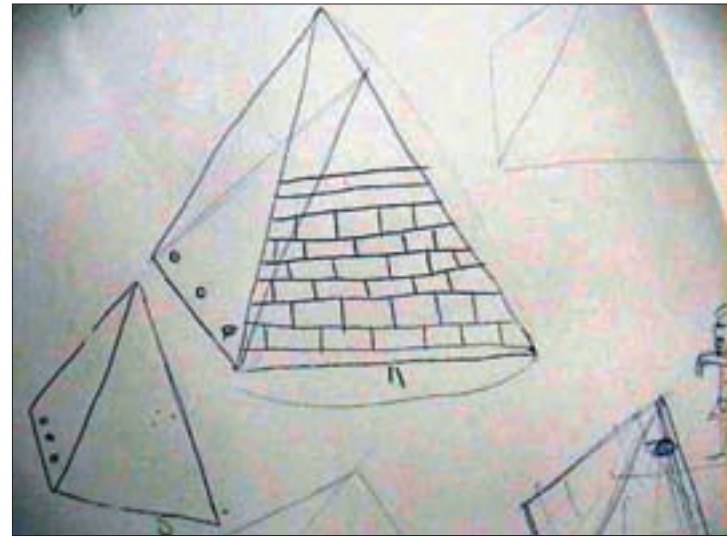

Gloria's pyramid sketches

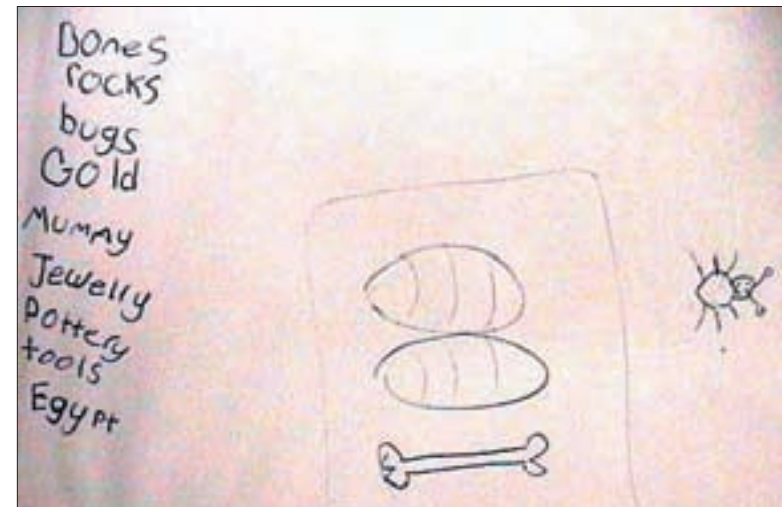

Gloria's notes



This lesson begins the process of the actual book construction. Now that each student has their shape, everyone will begin constructing their book. The first part of the book building process is making the covers. In order to make the covers, we begin by creating a template. This template will be used not only to make the covers but in subsequent lessons will be used to make pages and folders for the books. The second stage of the cover making process involves tracing the template onto heavy board that will become the actual book covers. These first two stages are done by the students in class. In the third and final stage you will cut the covers for the students outside of class time due to the nature of the materials.

Up until this point students have been working collaboratively. Now they will begin working individually on their books. You will notice that the work becomes more technically demanding. **DO NOT DESPAIR!** We found that at times the students got overwhelmed with technical details and lost sight of the larger project. At such times we would break from the book construction, remind ourselves of the ultimate goal, and do a project that would later become part of the book. For example, it was part way through this lesson that the students made self portraits. This project became a page in the book when the book construction was complete.

We suggest reading through and/or doing all of the following steps prior to beginning this process with your students. Your sample will be a very useful guide and visual reference for them.

Skill

metric measurement in centimeters (cm)

Objectives

To design and cut the shapes for the front and back covers of the books.

Vocabulary

template- a pattern or mold that functions as a guide to the form or structure of something being made.

Materials

pencils with erasers
 poster board
 heavy board
 rulers with metric measurement
 scissors
 hole punchers
 razor blade (for teacher use only)
 drill (for teacher use only)

Activity

Part I: Creating the Template

1. Once the shape of the book is determined, have students decide on the size of their book. They can be specific with their ideas (for example, choosing a rectangle 35cm long x 28cm high) or more approximate in their decision making (to have a book about twice the size of a students' math text book.)
2. Each student should draw their shape on to the poster board by using exact metric measurement.

3. Students must decide from what side or point they want their book to open. Once they choose the opening side, add a margin of approximately 4-5cm to the length of the opening side. This is the space where the holes will be punched. (You can use this step as an opportunity to discuss the ways in which different cultures use books. Some open from the right, some from the left. Some cultures read their text vertically, others horizontally.)

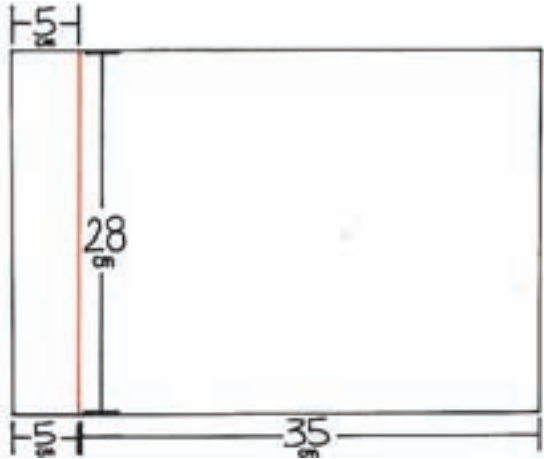

This rectangular example is based on a book that, with the added margin, is 40cm wide x 28 cm high.

In some cases you will have to be creative about how the book will open.

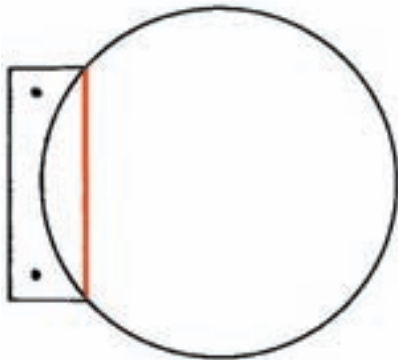

Note that Javier's book is a circle, and therefore has no straight side on which to add a straight length. We added to his drawn circle shape a rectangular piece on one side so that the book would be able to open from the left as a circle.

4. Each student now must decide how many holes to have for their book binding. For smaller size books, two holes works well. For larger size books we recommended three holes. The holes should be measured out at equal distances along the length of the opening side margin. Make sure that the holes closest to the top and bottom edges are at least 3cm in from the top and bottom.

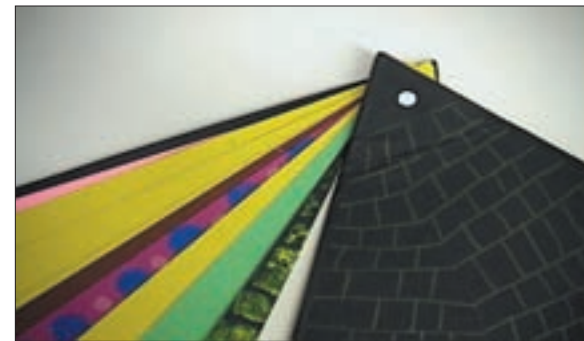
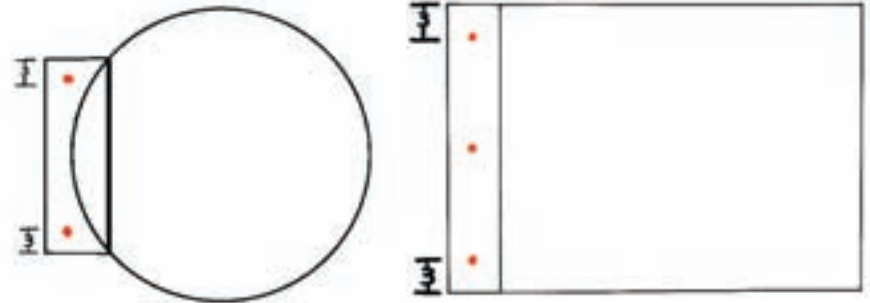

Note that Gloria chose the point of her pyramid to be her book opening so that it could fold open from the top or else open on a swivel. Gloria's book only required one hole.

5. Have students cut out their cover shape following their marked measurements.
6. Have students punch the holes that were marked with pencil on the poster board with the hole puncher:

Now students have a single template from which to make their front and back covers.

Part II: Tracing the Template

1. Have students trace their cut out template onto the heavy board two times, including the placement of the holes. Ask students to be as efficient with their space as possible. If their book has a straight edge, ask them to line up one side of their pattern with a straight edge of the board. Likewise, the side of one of the straight edges for one cover can be the straight edge for the second cover. This will save you, the teacher, much time and energy when cutting the boards with the razor blade or saw.
2. Label one of these traced covers “Front Outside”.
3. Now refer to the drawing in step #3 on the previous page. Notice the red line in the drawing. Students must replicate this line on the cover they have marked “Front Outside.” This drawn line is very important for you, the teacher, so you know where to score the book later on.

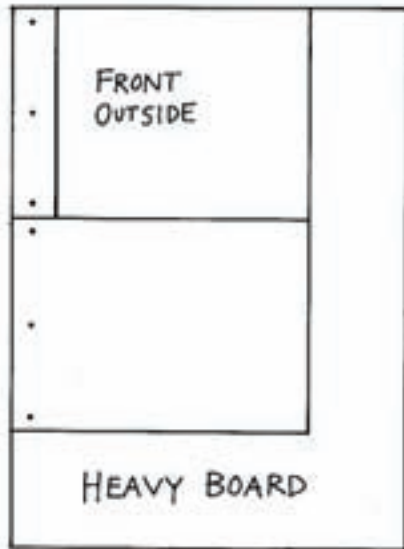

Have each student write their name on both of their book covers and on their original poster board template. Be sure to save each student's template. This will be useful for future lessons.

Part III: Cutting out the book covers: Teacher Preparation for the Next Class

Due to the heavyweight board used to make the book covers and the nature of the cutting involved, the next phase of the cover making requires some steps taken by you the teacher before the next class.

1. Following the students' markings, cut out the book covers with a razor blade. Use a hard ruler along the edges to cut a clean line. (If you have access to a band saw or automated cutting device, this would be even more efficient!!)

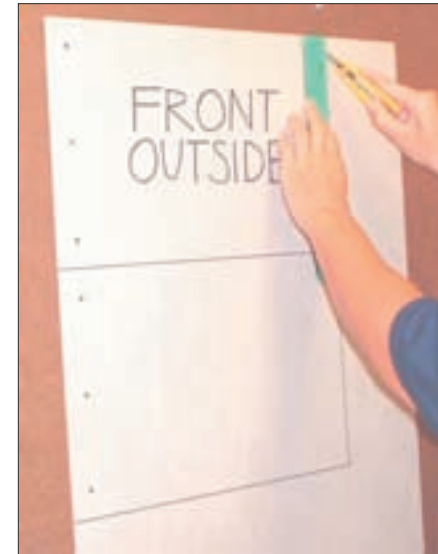

2. Drill holes according to the marks that students made previously. Make sure to use a drill bit of approximately 3/16 inch in diameter; the size of most bookmaking posts.



3. Flip the cover labeled “Front Outside” over and label it “Front Inside.” On the “Front Inside” redraw the red line previously drawn by the student on the Front Outside.



4. You will need to score the Front Inside according to this new line so that the cover will bend open. Along the line you have just drawn, use the razor blade to make a slice that does not go through the board but rather cuts it just enough to be able to bend the cover back.



Notice how the book cover bends with the score

Bring the book pieces to the next class so that students can put their books together:

Variation

Instead of using the heavy weight board that requires you to cut, use a light-weight board or poster board. Keep in mind that the lighter the material, the easier it is for students to cut but also the less durable it will be. Your choice will be based on the amount of time in and out of class you have to prepare for this project and the durability that you want the books to have.

Please note: even if you will have the students use poster board for the book covers, we still highly recommend making a template out of poster board and then tracing it onto another poster board that will be the covers. This will leave each student with a template necessary for future steps of the bookmaking project.

Lesson 6

Choosing Cover Colors



Now that each student has their covers cut out, there are a couple of more steps left to finish the book construction. In this lesson students will be cutting out colored construction paper that conforms to the shape of the covers, gluing it onto the covers, and lining the cover edges with tape for extra protection. We chose this method over painting directly on the cover boards to avoid the warping that can occur if paint is applied directly to the board.

As you read through this lesson plan, you will notice that finishing the book construction provides an opportunity to explore congruence and symmetry. Prior to slicing the inside of the front cover page and gluing the cover colors to the boards, each student will have a total of 6 shapes. You may want to use these shapes as manipulatives to explore the concepts of symmetry and congruence.

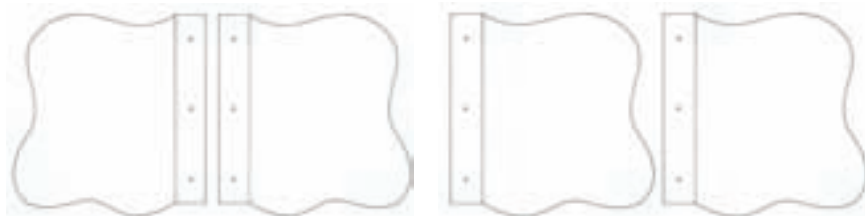

symmetry & congruence

congruence

Skill

understanding congruence, symmetry

Objective

To choose the cover colors, to complete the book construction

Vocabulary

congruence- having the same size and shape

symmetry- similarity of form on either side of a dividing line

Materials

student book cover pieces

thick paper or poster board

scissors

glue sticks

black masking tape (3-4cm) (The wider the tape, the more flexibility/
room for error.)

bookmaking posts (2-3cm long) (Found at office supply stores or
stationery shops.)

Activity

Part I: Choosing the cover colors and gluing them

Students must choose the colors for both the outsides and insides of their covers. Some students chose four different colors. Many students chose two colors: one color for the two outside covers and another for the two inside covers.

1. Have students trace their covers four times on the heavy weight paper or poster board according to their color choices. Make sure to mark exactly where the holes go. If a book is an irregular shape, or there is a chance that the two covers are slightly different, you might want to trace the front cover twice and the back cover twice as well, so that the papers will fit most accurately.
2. Have students cut out the colored papers and punch out the holes that they marked in step 1. At this point, each student has four papers and two original covers with which you can explore symmetry and congruence.
3. Have students glue the papers to the corresponding covers. Please note: The inside front cover is the one exception to this process. Because of the score in this side of the cover to allow for the bend where the book folds open, we recommend making a slice in the inside front cover paper; cutting it into two pieces. This will make the book easier to open for there will be less tension at the fold:



Part II: Lining the edges of the covers with black masking tape

This final step creates a really nice finished edge to the book and protects the edges from wear and tear. The wider the tape, the more flexibility/room for error a student has. (The following steps are based on a book 40cm wide and 28cm high with a black masking tape that is 2 cm wide.)

1. Cut a piece of black masking tape that is at least as long as the height of the book. Insert it into the wedge now in the inside front cover so that the tape helps to bind the slice made. Cut off any extra from the edges.



2. Cut another piece of black masking tape of the same length. Place this piece along the length where the book bends on the outside front cover for extra support. Cut off any extra from the edges.



3. Cut a piece of black masking tape, at least the length of the edge of the book that is the opening side. Lay the tape down so that about half of the width of the tape sticks to this edge. Fold the tape to the other side. Go over it several times with your fingers to make sure it sticks well. Trim off any extra tape hanging off the book edges.



4. Repeat step 3 for all other edges, including those of the back cover.



For any book with a rounded perimeter at any point such as a circle book, or Estefania's paint palette book for example, a bit more patience for the taping process is required. Instead of one long tape for each edge, you will need to cut many small pieces of tape to effectively tape around any curve(s).

1. First tape the margin and any other straight edges with black tape of the appropriate length as you would in steps 3-4 for a rectangular book.



2. For the curved edges, cut out a bunch of small pieces of tape each approximately 2-3 cm in length. Start at one end of the curve. Place about half the width of a piece of tape along the curved edge of the circle and fold under to the other side.

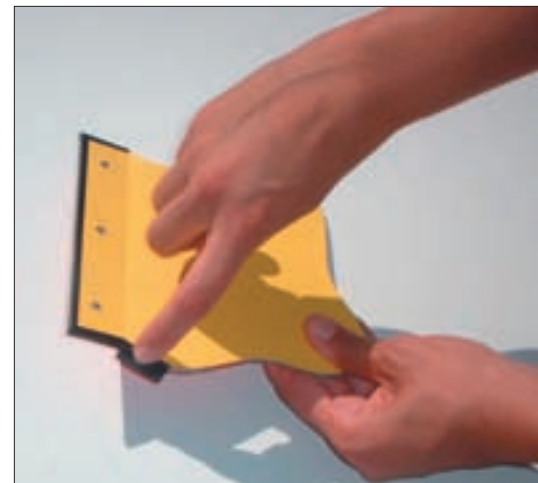

3. Repeat this with the next piece of tape so that it overlaps the previous piece of tape by just a little bit. Continue this process around the curve.

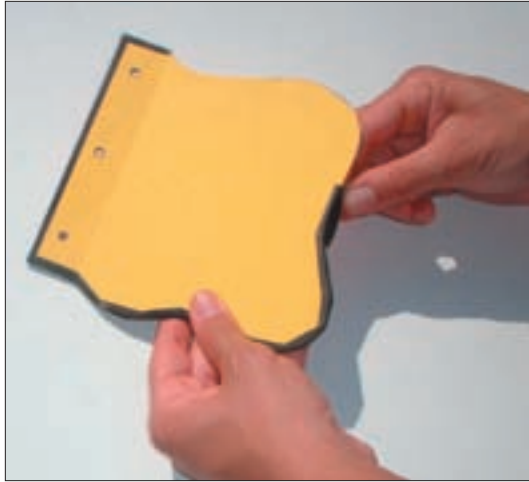

4. Complete this taping process for both the front and back covers.



Now insert the book making posts into each of the holes of the book as shown below, first through the front cover so that they come out the back cover. Screw the post end onto the post length. The posts can be unscrewed to take the book apart at any time to insert or remove pages.

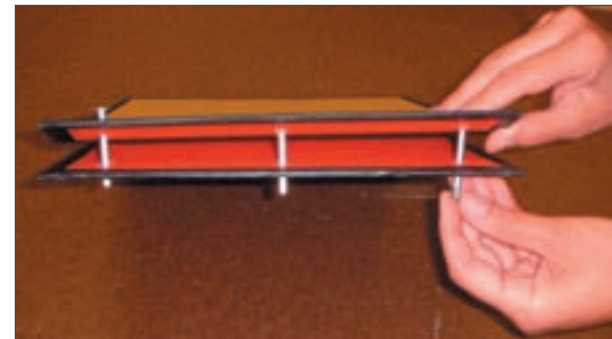
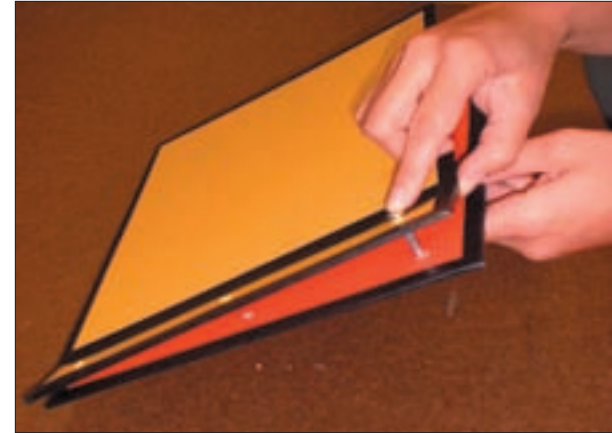

Congratulations! The book construction is now complete!

Decorating the Covers!



Now the students' books are ready to be decorated. In contrast to the previous lesson, "Decorating the Covers" is a much more open-ended and personalized experience. This activity can be done at any point for the remainder of the bookmaking section. You can devote an entire class or classes to the cover creation, or it can be worked on when students finish other lessons early. We suggest that the cover be continuously worked on in between the more rigorous, or lengthy activities still remaining in the book-making project. We found the students were very excited to have many opportunities to return to their cover creation.

Skill
personal expression

Objective
To complete the book covers by incorporating drawings, designs, or collage.

Vocabulary
collage- a design or picture made by gluing paper and other materials onto a surface

Materials
a variety of mark making materials:
pencil, crayons, markers, paints
material for collage
glue sticks
scissors



Ana's soccer ball book incorporates a photo of herself

Activity

Have students use a variety of mark making materials of their choice to add the drawings, designs, paintings, and/or collage to their covers. Students may want to remove the book posts for this part of the project so they can work on more than one side of a cover at a time.

Encourage students to be as original and involved as you have time for. Investment and pride in their books means that they will use them for a long time to come and have an important record of their dreams, visions, and ideas.

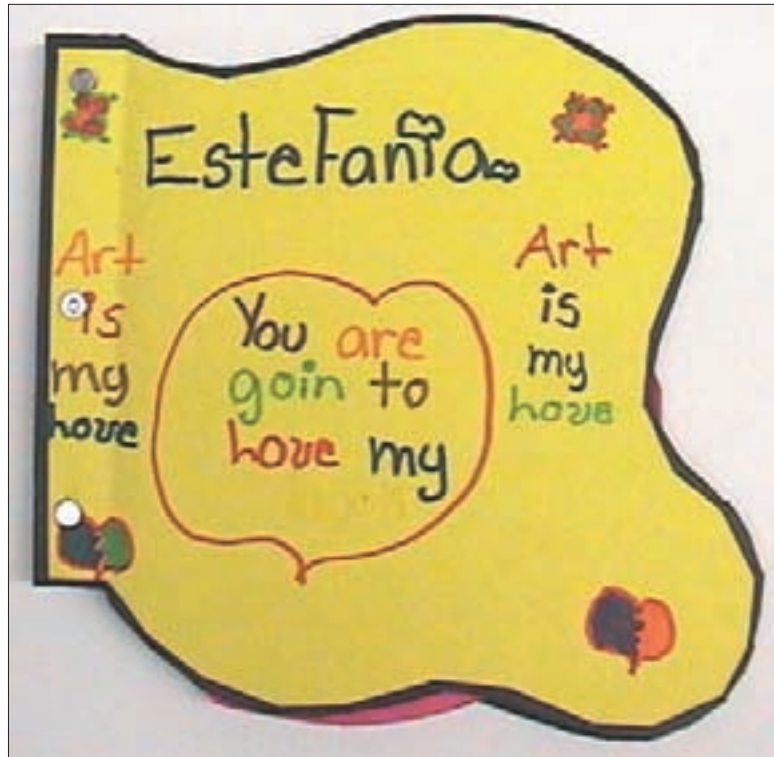

Estefania's paint palette



Dolores' cover in progress

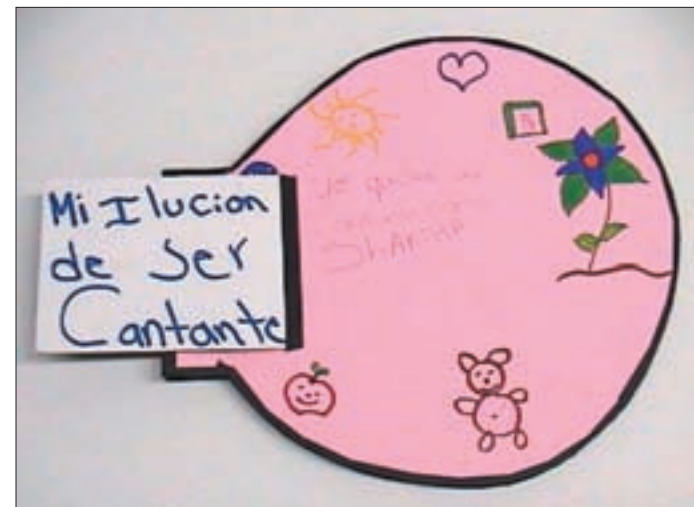

Dolores' "dream to be a singer" is revealed behind her picture



Ms. Maria has big dreams of being a teacher

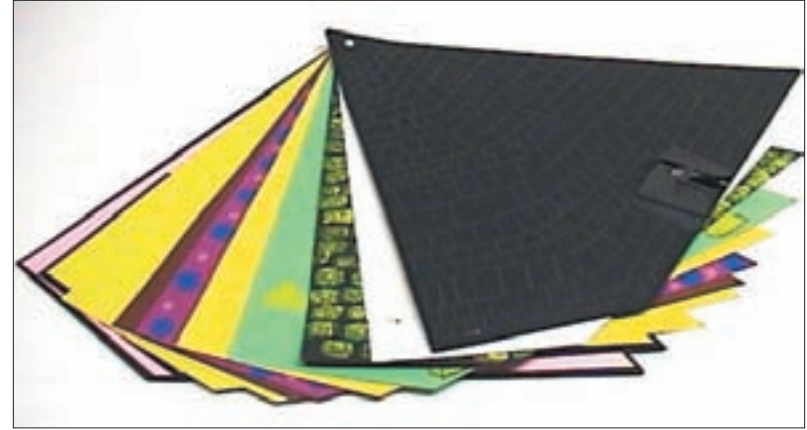

Gloria's pyramid book with swivel hinge



Gloria, the future archaeologist, and her treasure



Jasmine and her pentagon in progress

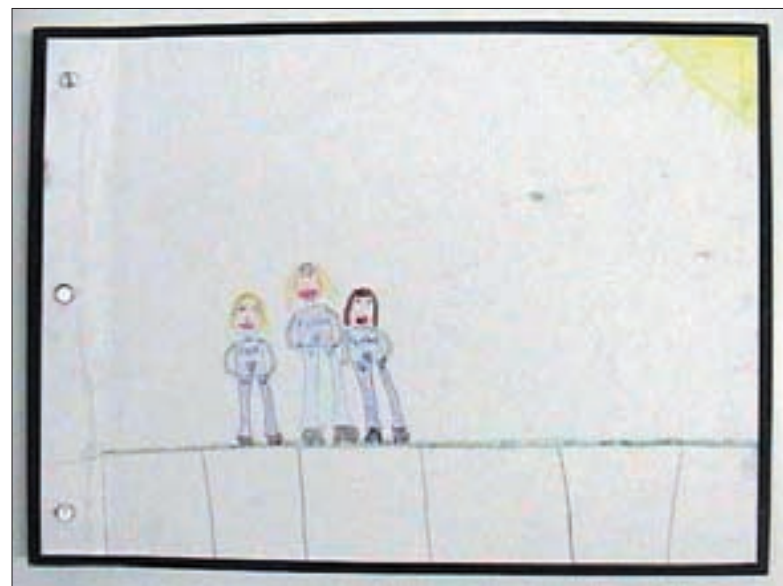

Miranda and her Metric Arts posse



Miranda expresses how she feels about Metric Arts

Making a Page Template



Now we are ready to make pages for the book. In order to make the pages a consistent size which fit between the covers we decided to create a page template. We found this to be a good exercise in approximate and exact measurement. It also provides a consistent and durable page sample that the student can use to create multiple accurately hole-punched pages for the book without re-measuring or guessing the page size each time they need additional pages. The template (and book pages) will be made smaller than the cover size so that when the book is closed and handled, the pages will not stick out but rather fit within the book covers and be protected. The template itself can be stored at the end of the book for easy access.

Skill

approximate and exact metric measurement in cm

Objective

To make a page template for the pages of the book.

Vocabulary

about- reasonably close to, approximately

template- a pattern or mold that functions as a guide to the form or structure of something being made

Materials

- pencils
- scissors
- poster board
- ruler with metric measurement
- hole puncher

Activity

Each student should have in front of them their poster board template used to trace the original book covers. It is from this original template that the page templates will be cut.

1. To practice approximation skills, draw lines along each side of the original template about every 5-7 cm.

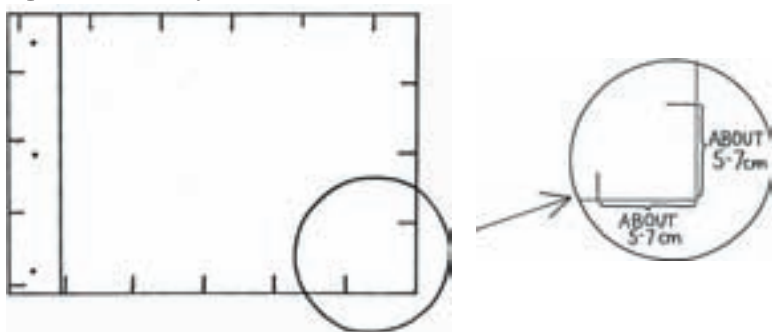

2. To practice exact metric measurement skills, mark a dot on these lines at exactly 1cm in from each edge of the pattern piece.

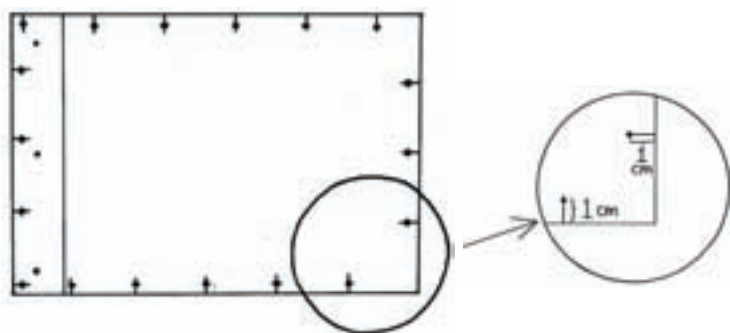

3. Connect the dots along each side of the pattern piece.



4. Cut along these new lines. Now each person has a page template appropriate to their original book size.

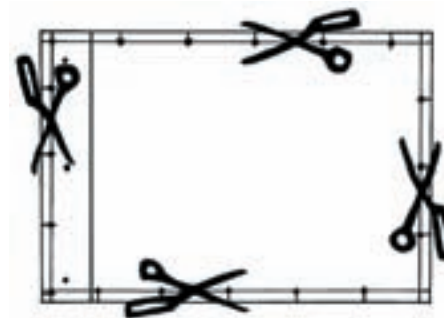

Make sure students clearly label their newly cut template "TEMPLATE". Students can use the rest of class time to trace this template onto pages that can then be cut out and hole-punched for future book pages.

Please note: For the circular book, the same steps are followed to place the dots, only around a curve. The connecting line between the dots can be made free hand. Or you can use a compass for a more exact circle.

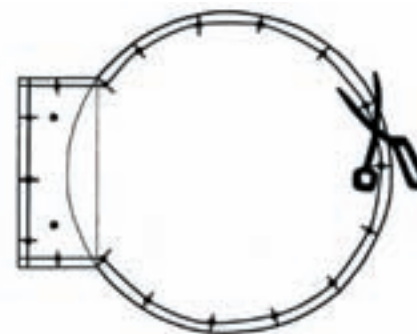

Lesson 9**Folders for Treasures!**

You may be working on art projects that are destined to be included in the book. What did students do with works in progress that had to be left for another day? They put them in the book's folder! The folder is meant to be a place where pieces of the evolving book can be temporarily left unfinished. Metaphorically, we can think of the book as a symbol of our evolving selves. Just as we are never truly finished beings, so the book is potentially a constantly evolving project.

Skill

metric measurement in centimeters (cm)

Objective

To create a place in the books for storage of small projects or works in progress.

Vocabulary

parallel- lying or moving in the same direction but always the same distance apart

perimeter- the boundary of a closed two dimensional figure

Materials

poster board

pencils

hole puncher

masking tape (available in various colors in hardware stores; 2-3cm. wide: the wider the tape the more flexibility/room for error)

Activity

Part I: Making the folder pieces

1. Trace the page template twice onto a piece of poster board. Make sure to mark where the holes are on both pieces. Ask students to be as efficient as possible with their space.



2. Cut out the two new templates and punch the holes. One of these will be the folder back and one will be the folder pocket.

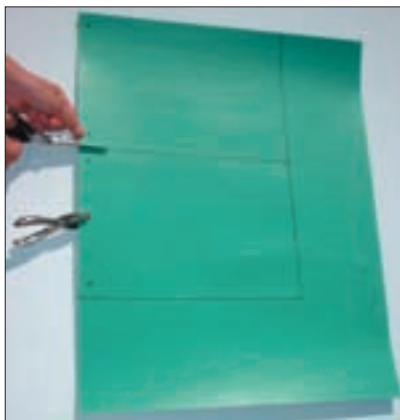

3. To make the folder pocket: on one new template, mark a point approximately 2 cm above the midpoint. (If the book has three evenly spaced holes, a good guide would be to find the spot somewhere above this middle hole.)



4. Draw a line through this point that is parallel to the bottom most side of the template.



If you want to emphasize the concept of parallel and have students make a parallel line using exact measurement, have them measure up x cm (in this example about 16cm) on the left side of the new template and mark a dot. Measure up and mark a dot at the same distance on the right side of the new template. Draw a line through the two dots. If students have measured correctly the line should be parallel to the bottom edge.

5. Cut along this line. What is below the line you have cut is the pocket of your folder.

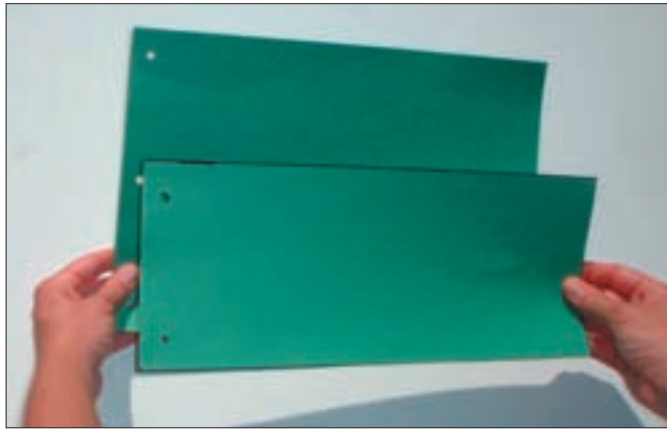

For a circle or a shape that is not a basic square or rectangle, an approximated parallel line can be made by estimating where a bottom edge would be and making the line parallel to it:

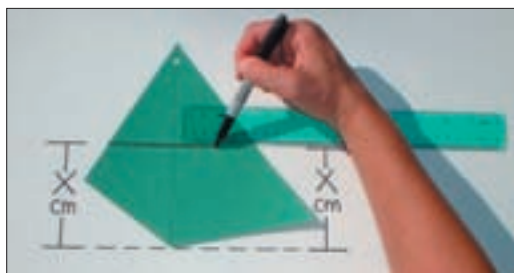
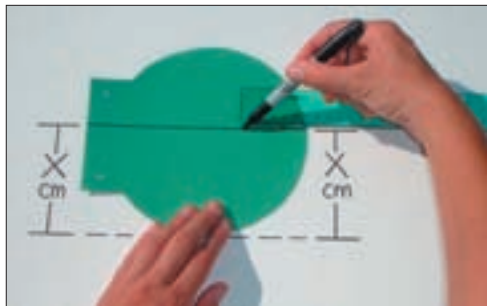

Part II: Taping the folder pieces

Now that each student has a folder back and a folder pocket, place the pocket on top of the back matching up the holes and tape them together along the edges in the following manner:

1. Place the tape so that about half of the width of the tape sticks to one edge. Fold the tape to the other side.

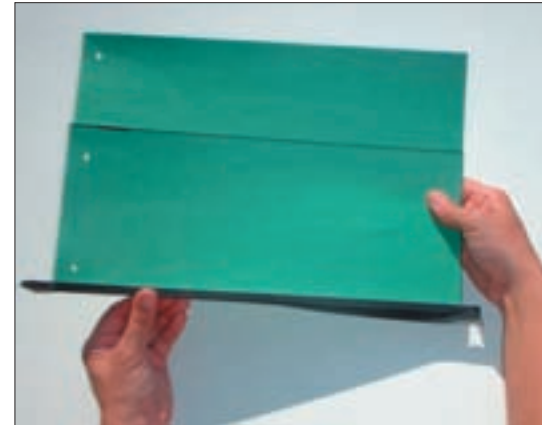

2. Trim off any extra tape from the corners

3. Repeat steps 1 and 2 for all other edges to complete your book folder:



For any book with a rounded perimeter (such as a circle book, for example), first tape and trim any straight edges in the same manner as described above. Then, tape the rounded edges as follows:

1. Cut out a bunch of small pieces of tape each approximately 2-3cm in length. Place the tape pieces around the curve(s) folding them under as you go.

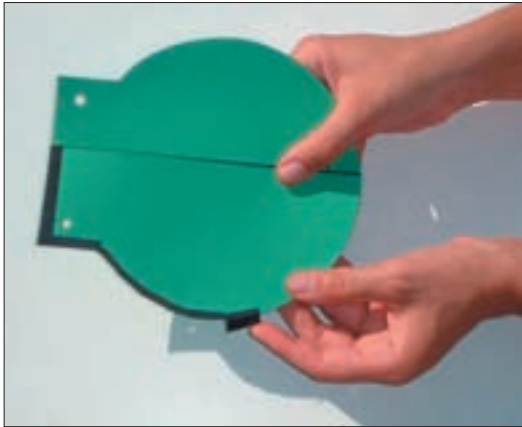

2. Continue this until all curved edges of the folder pocket and folder back are joined. Your folder is now complete!

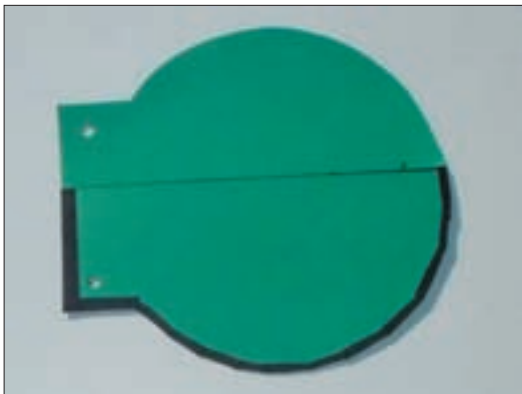

Completed folders can be inserted into the books to hold works in progress or for general storage.

Variation

- Students can make multiple folders in their books for multiple purposes.
- Folders can have pockets on both sides. In this case, trace an additional template piece as done in the initial step and cut and tape this pocket to the other side of the folder back.

Lesson 10 Mini Book Making

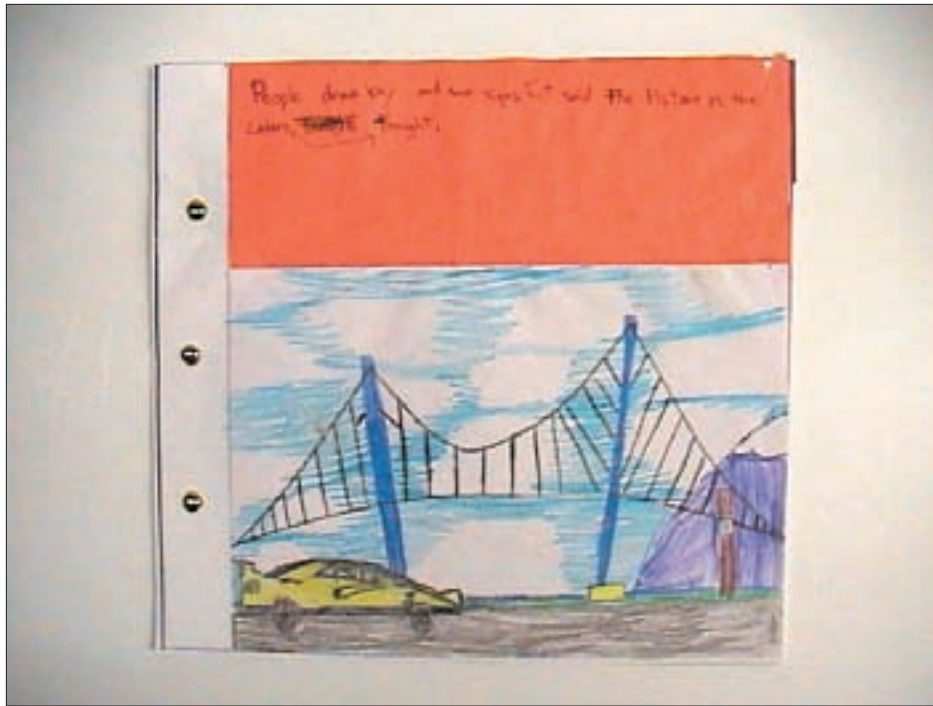

We've come a long way since we were looking at books to get ideas and inspiration. We decided to make "mini books" as a way to explore the possibilities for how words and image share a page. The "mini book" is a scaled down version of each person's book. These will become a place for future experimentation and for fun and interesting graphic design possibilities. The process requires students to deal with fractions, simple division, and visual scale. For the purpose of this lesson, each student will make a mini book that is $\frac{1}{4}$ the size of the original book. There are several ways to determine a book that is $\frac{1}{4}$ the size of the original book. Below are three ways that we brainstormed with our class to determine the dimensions of a book that is $\frac{1}{4}$ the size of the original.

Skill

fractions, metric measurement

Objective

To produce a mini book $\frac{1}{4}$ the size of the original book.

Vocabulary

fraction- a comparison of parts to a whole or to a set.

Materials

white paper
pencil
flexible measuring tape
compass (for any students making circular books)
hole puncher
gold brads

Activity

1. The dimensions of the example is a rectangular book measuring 40cm x 28 cm. To find a mini book $\frac{1}{4}$ this size, the length and width of the book must each be divided in half. In each instance of this example, the $\frac{1}{4}$ size mini book measures 20cm x 14 cm.



Method 1: Divide each length by 2

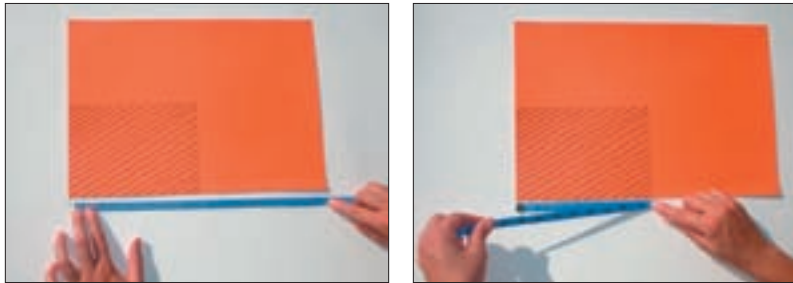

Method 2: Use a flexible measuring tape

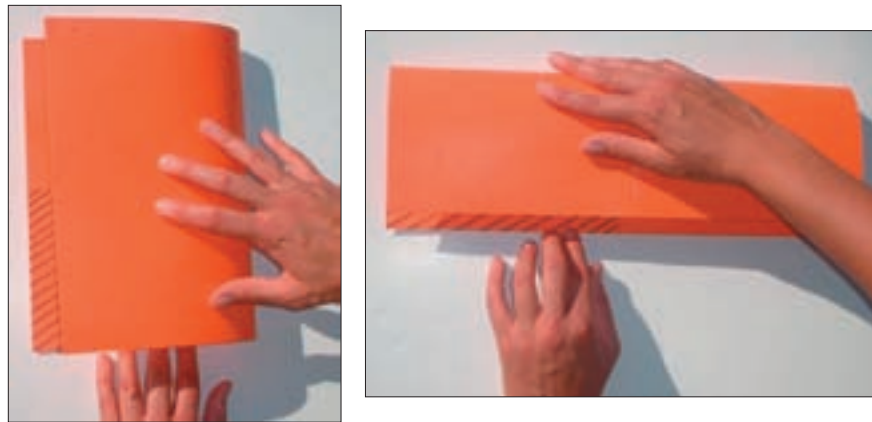

Method 3: Fold in half two times

2. Each student draws their mini book on a piece of white paper.
3. Students should place small circles on their mini book page approximately where the holes are on their original books.
4. Have students cut out the mini book page.
5. Using this mini book page as a guide, have students cut out multiple copies. We suggest students cut out 10-15 pages. They can cut out several at a time.
6. Punch out the holes in each of the pages.
7. Assemble the books by binding them with the gold brads.

For a circular book: Using a compass, place the point of the compass in the center of the circle and the pencil point of the compass at a point half way in between the midpoint and the circle's edge. Mark a new circle using the compass. This new circle is 1/4 the size of the original circle.

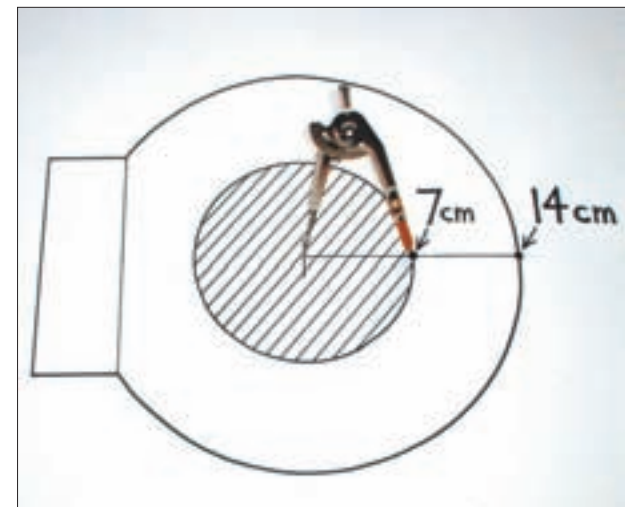

Follow-up Discussion

Have students share their opinions about the process of finding a mini book size $\frac{1}{4}$ that of the original book size

-Which of the brainstormed methods for finding a “ $\frac{1}{4}$ ” is most exact? Which method did you use? Why?



Now that the mini books are fully assembled, students are ready to use them as a place for experimenting with graphic designs. We began this lesson with a discussion about graphic design: the art of organizing images, words, and symbols on a page in order to communicate a message or idea. Recall with the students the “What do you love about books?” lesson, the class devoted to looking at books and the ways in which different writers and artists placed words and pictures in relation to one another on a page. In this lesson students will plan graphic possibilities for the books using a variety of cut out shapes. The pace of this exercise can be quite quick, and can serve as an ongoing place to brainstorm. The mini book is easily stored in the book folder and can be worked on at any time

Skill

Shape relationships

Objective

To brainstorm a variety of graphic design possibilities.

Vocabulary

graphic design- the art of organizing images, words, and symbols on a page in order to communicate a message or idea.

Materials

- copies of each student's mini book page
- construction paper of different colors
- scissors
- pencils
- rulers

Discussion

Talk with students about how the overall shape of their book can determine the smaller shapes that fit into it. Ask students to consider the edges of the book and how the shapes are organized in relation to them. Here are some questions you can brainstorm with your students on the board:

- If you have a rectangular book, what kinds of square and rectangular shapes can you fit into your book like a puzzle?
- How many combinations of squares and rectangles can you come up with?
- What about triangles? How can you make several triangles fit into the rectangular dimensions of the book?
- What about circles and shapes with rounded sides?
- How about shapes with both straight edges and rounded sides, such as a semi circle?
- What kinds of shapes can you invent to fit into these puzzles?

See the drawings below for variations on how you might brainstorm some of these ideas with your class on the board.

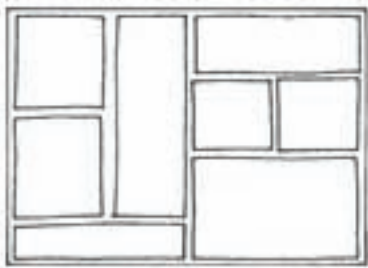

squares and rectangle combinations

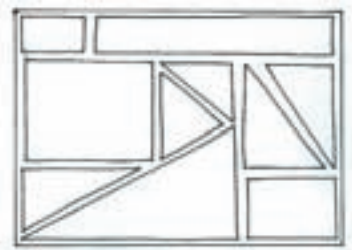

introducing triangles

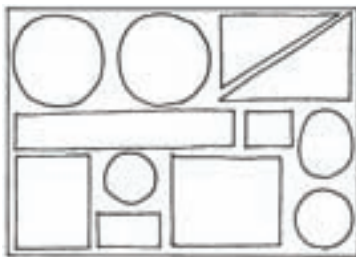

introducing circles



invented shapes

Activity

Each person should have their mini book in front of them. Now have students cut a variety of straight edged shapes and curved shapes of different sizes, out of colored construction paper:

In some cases students cut their shapes out in relation to the format of their mini book page. In other cases, students cut out a variety of shapes and then saw how or if they fit into their mini book page. Have students paste these shapes within the borders of the mini books experimenting with different arrangements and configurations.



Estefania's palette mini book

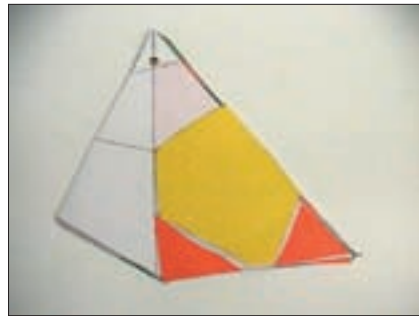
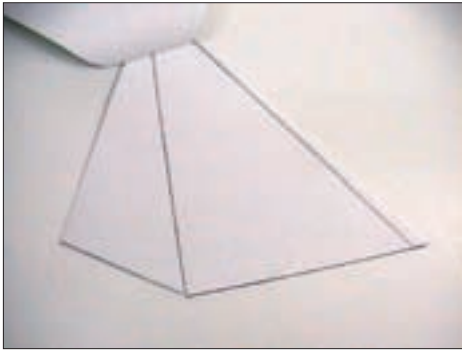

Gloria's pyramid series

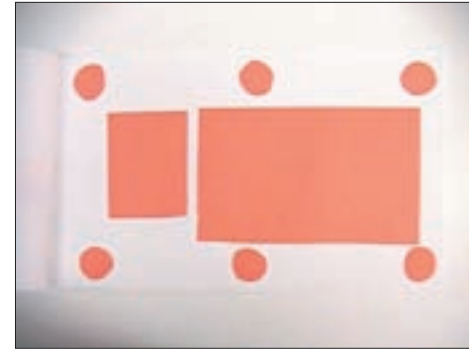

Maria's rectangles, triangles, and circles

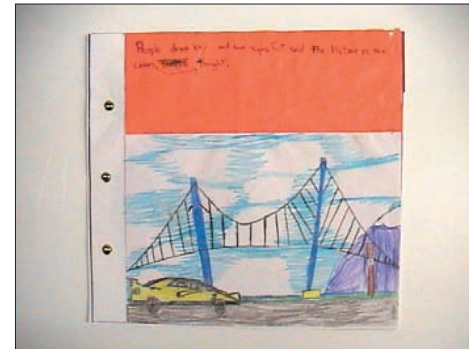

Joe's mini book sketch page



Gino's diamonds



Gino's playing with blocks



Gino's shape soup

Remind the students that the shapes they are organizing represent possibilities for the future placement of words and pictures in their book. The experimentation can go on forever; encourage students to be as fun and inventive as they can be. Once completed, the mini books serve as a source book for the different kinds of designs for pages of the book.

A Conclusion to Bookmaking...

Finally! The construction of the books is a huge accomplishment. So, the books are complete - or have they only begun? Now that students have so carefully used their metric skills to build a book, it's time to continue making work that can be kept in the book as a record of their dreams and aspirations. The posts allow the creators to add, remove, or change the order of the pages any time. Just as our identities and selves are a constantly evolving and dynamic work in progress, additions to the content of the book are always welcome.

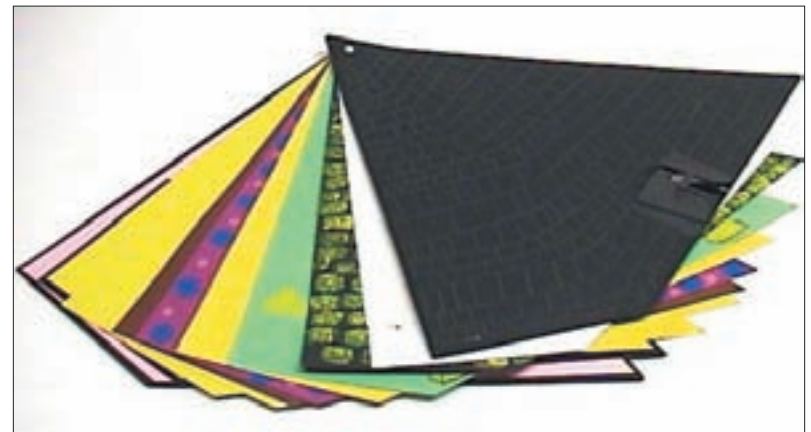

Gloria's pyramid book

